

ELGAR

400SD/SP

OSCILLATOR

Instruction Manual

ELGAR ELECTRONICS CORPORATION

9250 Brown Deer Road
San Diego, CA 92121-2294
1-800-733-5427
Tel: (858) 450-0085
Fax: (858) 458-0267
Email: sales@elgar.com
www.elgar.com

©1985 by Elgar Electronics Corporation

This document contains information proprietary to Elgar Electronics Corporation. The information contained herein is not to be duplicated or transferred in any manner without prior written permission from Elgar Electronics Corporation.

August 1985

Document No. 604-203-90 Rev A

ELGAR TWO-YEAR WARRANTY

Elgar Electronics Corporation (hereinafter referred to as Elgar) warrants its products to be free from defects in material and workmanship. This warranty is effective for two years from the date of shipment of the product to the original purchaser. Liability of Elgar under this warranty shall exist provided that:

- the Buyer exposes the product to normal use and service and provides normal maintenance on the product;
- Elgar is promptly notified of defects by the Buyer and that notification occurs within the warranty period;
- the Buyer receives a Return Material Authorization (RMA) number from Elgar's Repair Department prior to the return of the product to Elgar for repair, phone 800-73-ELGAR (800-733-5427), ext. 2295;
- the Buyer returns the defective product in the original, or equivalent, shipping container;
- if, upon examination of such product by Elgar it is disclosed that, in fact, a defect in materials and/or workmanship does exist, that the defect in the product was not caused by improper conditions, misuse, or negligence; and,
- that Elgar QA seal and nameplates have not been altered or removed and the equipment has not been repaired or modified by anyone other than Elgar authorized personnel.

This warranty is exclusive and in lieu of all other warranties, expressed or implied, including, but not limited to, implied warranties of merchantability and fitness of the product to a particular purpose. Elgar, its agents, or representatives shall in no circumstance be liable for any direct, indirect, special, penal, or consequential loss or damage of any nature resulting from the malfunction of the product. Remedies under this warranty are expressly limited to repair or replacement of the product.

CONDITIONS OF WARRANTY

- To return a defective product, contact an Elgar representative or the Elgar factory for an RMA number. Unauthorized returns will not be accepted and will be returned at the shipper's expense.
- For Elgar products found to be defective within thirty days of receipt by the original purchaser, Elgar will absorb all ground freight charges for the repair. Products found defective within the warranty period, but beyond the initial thirty-day period, should be returned prepaid to Elgar for repair. Elgar will repair the unit and return it by ground freight pre-paid.
- Normal warranty service is performed at Elgar during the weekday hours of 7:30 am to 4:30 pm Pacific time. Warranty repair work requested to be accomplished outside of normal working hours will be subject to Elgar non-warranty service rates.
- Warranty field service is available on an emergency basis. Travel expenses (travel time, per diem expense, and related air fare) are the responsibility of the Buyer. A Buyer purchase order is required by Elgar prior to scheduling.
- A returned product found, upon inspection by Elgar, to be in specification is subject to an inspection fee and applicable freight charges.
- Equipment purchased in the United States carries only a United States warranty for which repair must be accomplished at the Elgar factory.

ELGAR

Committed to Quality...Striving for Excellence

TABLE OF CONTENTS

SECTION I

GENERAL INFORMATION

1.1	Introduction.....	1-1
1.2	Scope of Manual.....	1-1
1.3	General Description of Operation.....	1-1
1.4	Resistance Programming.....	1-3
1.5	Voltage Programming.....	1-3
1.6	Tandem Operation.....	1-3
1.7	Specifications.....	1-3

SECTION II

PRELIMINARY INSPECTION AND OPERATION

2.1	Inspection Upon Receipt.....	2-1
2.2	Installation.....	2-1
2.3	Operation.....	2-1
2.4	Interconnections For Two or Three Phase Operation.....	2-2

SECTION III

THEORY OF OPERATION

3.1	Oscillator Circuit.....	3-1
3.2	Multi-Phase Option.....	3-2
3.3	Frequency Detector Circuit (Model 400SD Only).....	3-2

SECTION IV

MAINTENANCE

4.1	Service Information.....	4-1
4.2	Factory Service.....	4-1
4.3	Shipping Damage.....	4-1
4.4	Single Phase Calibration.....	4-1
4.5	Phase Board Calibration.....	4-2
4.6	Resistance Programming Calibration.....	4-3
4.7	Voltage Programming Calibration.....	4-3
4.8	Circuit Board Component Location.....	4-3
4.9	Test Equipment Required.....	4-3

SECTION V

DIAGRAMS

5.1	General.....	5-1/5-2
-----	--------------	---------

TABLE OF CONTENTS (Continued)

5.2 Diagrams..... 5-1/5-2

SECTION VI

REPAIR PARTS LIST

6.1 General..... 6-1
6.2 Spare Parts Ordering..... 6-1

LIST OF TABLES

1-1 Specifications..... 1-3

LIST OF ILLUSTRATIONS

1-1 Switch Code..... 1-2
2-1 2 Amplifier 3Ø Wye Configuration..... 2-2
2-2 Typical Plug-In Oscillator/Power Source Interconnection 2-3
3-1 400SD/SP Block Diagram..... 3-3
3-2 Timing Diagram..... 3-4
5-1 Model 400SD/SP Main Board Schematic..... 5-3/5-4
5-2 Model 400SD/SP Main Board Assembly Drawing..... 5-5/5-6
5-3 Model 400SD/SP Phase Board Schematic..... 5-7/5-8
5-4 Model 400SD/SP Phase Board Assembly Drawing..... 5-9/5-10
Model 400SD/SP Servo Board Schematic (Optional).....
Model 400SD/SP Servo Board Assembly Drawing (Optional)

COMPLETION OF THE 400SD OR 400SP MODEL NUMBER

"THREE DIGIT OPTIONS CODE"

400SD-

MODEL 400SD OR 400SP

0 - No external programming

1 - External resistance programming
0 to 13K ohm for 0 to full scale

2 - External voltage programming
0 to 10VDC for 0 to full scale

3 - External voltage programming
0 to 13VDC for 0 to 130V output

4 - External voltage programming
0 to 26VDC for 0 to 260V output

5 - External resistance programming
0 to 10K ohm for 0 to 130V output

0 - No remote sense with servo control

1 - 1 Phase remote sense with servo control

2 - 2 Phase remote sense with servo control

3 - 3 Phase remote sense with servo control

4 - 3 Phase open DELTA

5 - 3 Phase open DELTA remote sense with servo control

6 - Local front panel control for output range change

1 - 0 to 130V output of power source

2 - 0 to 260V output of power source

3 - 0 to 32V output of power source

4 - 0 to 65V output of power source

5 - Frequency range of 400SD extended
to 15Hz to 10KHz

6 - 15Hz to 5KHz extended range

7 - 45Hz to 10KHz extended range

Note that options -001, -002, -003 and -004 have no impact on the 400SD or 400SP oscillators themselves and are only used for general clarification of the power amplifier and oscillator combinations.

SAMPLE MODEL NUMBERS:

401SD-111	Single Phase, resistance program, servo control 0-130V output
403SP-400-402	Three Phase, fixed 400Hz, voltage programming 0-26VDC, no servo control, 0-260V output
403SD-103	Three Phase, resistance programming, 0-13K ohms, no servo control, 0-32V output
401SD-002	Standard oscillator with no options indicating that the accompanying power amplifier jumpered for the 0-260VAC output voltage.

Refer to Section I for operational descriptions of optional features.

MODEL 400SD/SP OPTIONS

1. EXTERNAL RESISTANCE PROGRAMMING OF OUTPUT AMPLITUDE:
 - a. 0 to 13K ohms for 0 to full scale
(100 ohms per volt for 130 volt output)
Note that three phase is simultaneous control.
 - b. Includes J1 mating connector P/N 856-112-9M 1 each Molex connector.
856-111-8M 12 each Female Pins.
2. EXTERNAL VOLTAGE PROGRAMMING OF OUTPUT AMPLITUDE:
 - a. 0 to 10 volts input for 0 to full scale output
 - b. 0 to 13 volts input for 0 to 130 volt output
 - c. 0 to 26 volts input for 0 to 260 volt output
 - d. Includes J1 mating connector P/N 856-112-9M 1 each Molex Connector.
856-111-8M 12 each Female Pins.
 - e. Note that in three phase systems the external voltage controls all three phases simultaneously.
3. REMOTE SENSE OF OUTPUT AMPLITUDE WITH SERVO CONTROL: SINGLE PHASE**
 - a. Requires remote sense cable 998-091-90 for 1 unit
 - b. Requires remote sense cable 998-098-90 for 2 units
4. REMOTE SENSE OF OUTPUT AMPLITUDE WITH SERVO CONTROL FOR TWO PHASE OR THREE PHASE**
 - a. Servo control is for each phase line to neutral
 - b. Two phase requires remote sense cable 998-092-90 for 1 unit
 - c. Two phase requires remote sense cable 998-090-90 for 2 units
 - d. Three phase requires remote sense cable 998-093-90 for 1 unit
 - e. Three phase requires remote sense cable 998-089-90 for 3 units
5. RESISTANCE PROGRAMMING & REMOTE SENSE FOR SINGLE PHASE**
 - a. Combines 1 and 3
 - b. Requires remote sense cable 998-103-90 for 1 unit
 - c. Requires remote sense cable 998-104-90 for 2 units
6. VOLTAGE PROGRAMMING & REMOTE SENSE FOR SINGLE PHASE:
 - a. Combines 2 and 3
 - b. Requires remote sense cable 998-103-90 for 1 unit
 - c. Requires remote sense cable 998-104-90 for 2 units

7. RESISTANCE PROGRAMMING & REMOTE SENSE FOR TWO OR THREE PHASE **

- a. Combines 1 and 4
- b. Servo control is for each phase line to neutral
- c. Two phase requires remote sense cable 998-105-90 for 1 unit
- d. Two phase requires remote sense cable 998-106-90 for 2 units
- e. Three phase requires remote sense cable 998-107-90 for 1 unit
- f. Three phase requires remote sense cable 998-108-90 for 2 units

8. VOLTAGE PROGRAMMING & REMOTE SENSE FOR TWO & THREE PHASE **

- a. Combines 2 and 4
- b. Servo control is for each phase line to neutral
- c. Two phase requires remote sense cable 998-105-90 for 1 unit
- d. Two phase requires remote sense cable 998-106-90 for 2 units
- e. Three phase requires remote sense cable 998-107-90 for 1 unit
- f. Three phase requires remote sense cable 998-108-90 for 3 units

**The REMOTE SENSE OF OUTPUT AMPLITUDE WITH SERVO CONTROL options provide the following voltage control specifications:

- 1. Load Regulation: +/- 0.015% of full scale change from no load to full load at point of sense
- 2. Line Regulation: +/- 0.01% of full scale change for a 10% line change within normal input line range.
- 3. Amplitude Temperature Coefficient: +/- 0.01% per degree C average 0 degree C to 50 degrees C
- 4. Remote sense with servo control options require separately priced remote sense cables:

- a. 1 Phase (single unit, e.g., 251B).....998-091-90
- b. 1 Phase (single unit with R or V Programming).....998-103-90
- c. 1 Phase (2 units, e.g., 6000-1).....998-098-90
- d. 1 Phase (2 units with R or V Programming).....998-104-90
- e. 2 Phase (single unit, e.g., 153B).....998-092-90
- f. 2 Phase (single unit with R or V Programming).....998-105-90
- g. 3 Phase (single unit, e.g., 1753B).....998-093-90
- h. 3 Phase (single unit with R or V Programming).....998-106-90
- i. 2 Phase (2 units, e.g., 240-2).....998-090-90

- j. 2 Phase (2 units with R or V Programming).....998-107-90
- k. 3 Phase (3 units, e.g., 3000-3).....998-089-90
- l. 3 Phase (3 units with R or V Programming).....998-108-90

NOTE: All amplitude measurements and accuracies based on full wave average.

Note that options -001, -002, -003 and -004 have no impact on the 400SD or 400SP oscillators themselves and are only used for general clarification of the power amplifier and oscillator combinations.

SAMPLE MODEL NUMBERS:

- 401SD-111 Single Phase, resistance program, servo control
0-130V output
- 403SP-400-402 Three Phase, fixed 400Hz, voltage programming
0-26VDC, no servo control, 0-260V output
- 403SD-103 Three Phase, resistance programming, 0-13k ohms,
no servo control, 0-32V output
- 401SD-002 Standard oscillator with no options indicating
that the accompanying power amplifier jumpered
for the 0-260VAC output voltage.

ADDENDUM

The Model 401SD-005 is a modified version of the Standard Variable Oscillator.

The frequency range of this oscillator has been extended and is variable from 15 HZ to 10 KHZ. This extended range is accomplished by replacing R19 (90.9Kohm) with a 332Kohm resistor and removing C12 on the Synthesized board.

Document Number: 604-203-90

Model Affected: 400SD/SP w/Servo

Description of Change:

The various models of the 400SD/SP oscillators may be enhanced by the addition of a servo board which allows the voltage at the load to be sensed and corrected for load variations.

DANGER - HIGH VOLTAGE is exposed when Power Source Top Cover is removed for servicing or calibration.

Resistance and Voltage programming are covered in the basic 400SD/SP Manual so they will not be covered in this text except for understanding when they are combined with a servo board.

Circuit Description

With a single phase servo installed, R54 on the basic oscillator board has been removed and the input side is now connected to the servo board (Schematic 604004) A PHASE INPUT. The ServoBoard A \emptyset output is now connected to the right side of where R54 was located. Thus a variable gain amplifier has been added in series with the A phase output. This is servo board U6 pins 1,2 and 3.

The IOV input to the servo board comes from the internal reference of the basic oscillator. It is dropped to 6.9 volts by CR1 and then boosted back to 10 volts by U10 pins 5,6 and 7. This is done to create a very stable (.004 percent per degree C) reference. This is sent back to the basic oscillator via 10V RET to be used as the reference for amplitude control.

The output of the reference amplifier is returned to the servo board via the -REF input. This same reference is used to control the output amplitude of Digital to Analog Converter, U14 in the basic oscillator. This output is returned to the servo board via A phase input.

When there is an open servo condition, U6 Pin 7 will be maximum positive due to the output of U10 Pin 1. This will cause photomodulator U5 to have minimum resistance between pins 5 and 6. This in turn will cause U6 pins 1,2 and 3 to have maximum gain.

When the servo feedback is connected, it appears at servo board R6 and R7. Intergrated circuit U13 and associated components form a Differential Amplifier with a rectified output. This feedback will cause U6 pin 7 to move in a negative direction until the output gain at U6 pin 1 is reduced to the point where there is circuit equilibrium.

SECTION I GENERAL INFORMATION

1.1 INTRODUCTION

1.1.1 The Series 400SD variable frequency oscillators are plug-in units which provide variable frequency signals for the Elgar AC Power Sources. The frequency is determined by four decade switches on the front panel.

1.1.2 The Series 400SP oscillators are plug-in units which provide fixed frequency signals for the Elgar AC Power Sources. The frequency may be changed by setting DIP switches internal to the oscillator.

1.1.3 The output amplitude of the 400SD or the 400SP is uncalibrated and is adjusted by the gain potentiometer on the front panel of the associated power source.

1.2 SCOPE OF MANUAL

1.2.1 This manual describes the Elgar Series 400SD and Series 400SP oscillators. It includes specifications, operating instructions, circuit descriptions, circuit diagrams, maintenance information and parts lists.

1.3 GENERAL DESCRIPTION OF OPERATION

1.3.1 The 400SD oscillator plugs into the front panel of the Elgar power source and is secured by two captive screws. Frequency output of the Model 400SD is controlled by four decade switches and a X1, X10, X100 frequency range switch. The decimal for reference is silkscreened on the oscillator front panel between the center two decade switches. Frequency resolution is 1 part in 10,000.

The frequency limit LED on the front panel of the oscillator will light if a frequency below 44 Hz or a frequency above 5100 Hz is selected. If this occurs, the output of the oscillator will drop to zero. When a proper frequency is selected, the Limit light will go out and the oscillator output will rise at an exponential rate to full output in about 250 milliseconds.

1.3.2 The 400SP oscillator plugs into the front panel of the Elgar Power Source and is secured by two captive screws. Frequency output is controlled by two 8 position DIP switches which are internal to the oscillator. These are inverted logic, thus the off position of the switch enables the bit. The code for these switches is shown in Figure 1-1. The Range is set by a jumper which is also shown in Figure 1-1. The X1 to Com sets the 45 to 99.99 Hz range, the X10 to Com sets the 45 to 999.9 Hz range and the X100 to Com sets the 45 Hz to 5 kHz range.

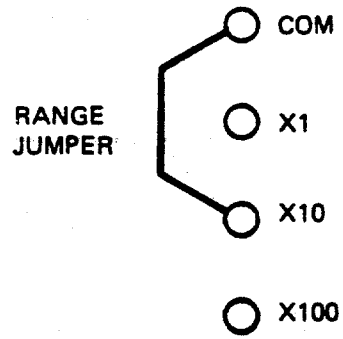

NOTE: Inverse logic = OFF = Set Bit

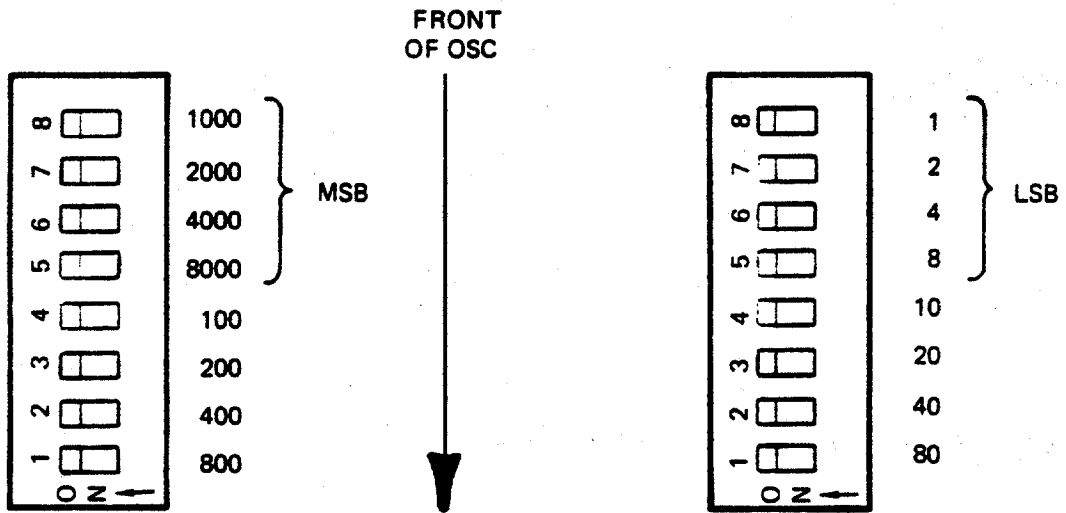

Figure 1-1

1.4 RESISTANCE PROGRAMMING

1.4.1 When the Model 400SD/SP has been equipped for resistance programming, the output amplitude of the power source may be varied by changing the value of an external resistor connected between Pins 7 and 8 of connector J1 on the rear of the power source. The value of this resistor is 100 ohms per volt on the 130V output range and 50 ohms per volt on the 260V output range. The associated power source will have the Gain knob removed and a shaft lock installed. This potentiometer now becomes the full scale calibration and R8 in the oscillator is 10% of scale calibration. Note: In the Model 400SD these calibrations will be affected by changing frequency.

1.5 VOLTAGE PROGRAMMING

1.5.1 When a Model 400SD/SP is equipped for voltage programming, the output of the power source may be controlled by a positive input voltage applied to Pin 6 with common to Pin 1 of J1 on the rear of the power source. The associated power source will have the Gain knob removed and a shaft lock installed. This is the full scale adjustment for voltage programming and may be set so that +10 volts equals 130V out or where +13V equals 130V out. This also applies to the 260V output range where +10V equals 260V or +26 equals 260V out. The 10% of the FS adjustment is R8 on the oscillator.

1.6 TANDEM OPERATION

1.6.1 All model 400SD/SP are equipped for tandem operation. Pins 9 and 14 of the oscillator are connected together.

1.7 SPECIFICATIONS

1.7.1 Specifications for the Series 400SD/SP are listed in Table 1-1.

TABLE 1-1. SPECIFICATIONS

Output Signal Amplitude	Approximately 2V RMS
Harmonic Distortion	Less than 0.25% of oscillator output 45 Hz to 5 kHz
Frequency Accuracy	±0.001% of set value
Temperature Coefficient: Of output frequency Of output amplitude	±0.0003%/°C ±0.02%/°C
Frequency Ranges	X1 Range 45 Hz to 99.99 Hz X10 Range 45 Hz to 999.9Hz X100 Range 45 Hz to 5000 Hz*
MODEL 401SD/SP 402SD/SP 403SD/SP	OUTPUT CONFIGURATION 1 Phase 2 Phase 3 Phase

*In Series 400SD this will be set to conform with upper full power frequency limit of associated power source and can be disabled for operation to 9999 Hz.

SECTION II PRELIMINARY INSPECTION AND OPERATION

2.1 INSPECTION UPON RECEIPT

2.1.1 The Elgar plug-in oscillators are aligned, calibrated, and tested prior to shipment. The instrument is therefore ready for immediate use upon receipt. The following checks should be made however, to assure the instrument has suffered no damage during shipment.

2.1.2 Make a visual inspection of the shipping container prior to accepting the package from the carrier. If extensive damage to the shipping container is evident, a description of the damage should be noted on the carrier's receipt, and signed by the driver or carrier agent. If damage is not apparent until the instrument is unpacked, a claim for concealed damage should be placed with the carrier and all shipping containers and filler material saved for inspection. Forward a report of damage to the Elgar Repair Department, who will provide instructions for repair or replacement of the instrument.

2.1.3 Visually inspect instrument for physical damage when it is removed from shipping container. Test functional operation of instrument as soon as possible. If damage is evident, or instrument does not function properly, notify the carrier immediately. Carrier's claim agent will prepare a report of damage to be forwarded to the Elgar Repair Department. You will be advised as to the action necessary to have the instrument repaired or replaced.

2.2 INSTALLATION

2.2.1 The oscillator is quickly and easily installed by plugging it into the space provided on the front panel of the Elgar power source. When the oscillator is fully inserted, and the captive screws secured, the unit is ready for operation.

NOTE

Remove power from amplifier when installing oscillator.

2.3 OPERATION

2.3.1 After installation in the Elgar power source, the oscillator operates automatically, receiving its power from the power source and requiring only that the front panel controls be set for the desired frequency and range. The amplitude of the power source output is controlled by the AMPLITUDE control on the front panel of the power source.

2.4 INTERCONNECTIONS FOR TWO OR THREE PHASE OPERATION

2.4.1 Three-phase oscillator may be installed directly in Elgar three-phase power sources without special connections. Where two-phase or three-phase power sources are made up by stacking two or three of the Elgar single-phase power sources, the oscillator is installed in the A-phase power source. Oscillator signals are carried to the B-phase and C-phase power sources through a cable (furnished with the oscillator) interconnecting the Jones S312AB sockets on the rear panels of the power source. The B-phase and C-phase sources must have Model 400B and 400C dummy plug-ins installed to complete the signal interconnection. The front panel AMPLITUDE control on the A-phase power source acts as a master control to vary all the outputs simultaneously, while the B-phase and C-phase AMPLITUDE controls act merely as balance controls to set the B-phase and C-phase output voltages equal to the A-phase output voltage.

2.4.2 With those single-phase Elgar power sources which have dual output windings, two power sources may be interconnected for three-phase wye operation. One of the output windings on each of the A-phase and B-phase sources is used for the A-phase and B-phase outputs. The C-phase output is synthesized by inverse series connection of the remaining two windings, as diagrammed in Figure 2-1.

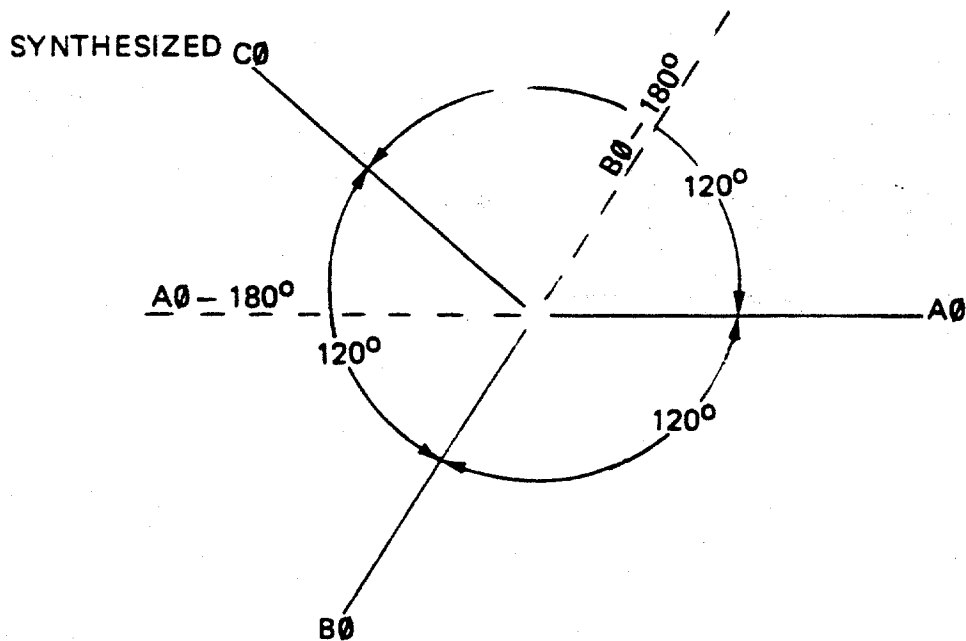

Figure 2-1. 2 Amplifier 3Ø Wye Configuration

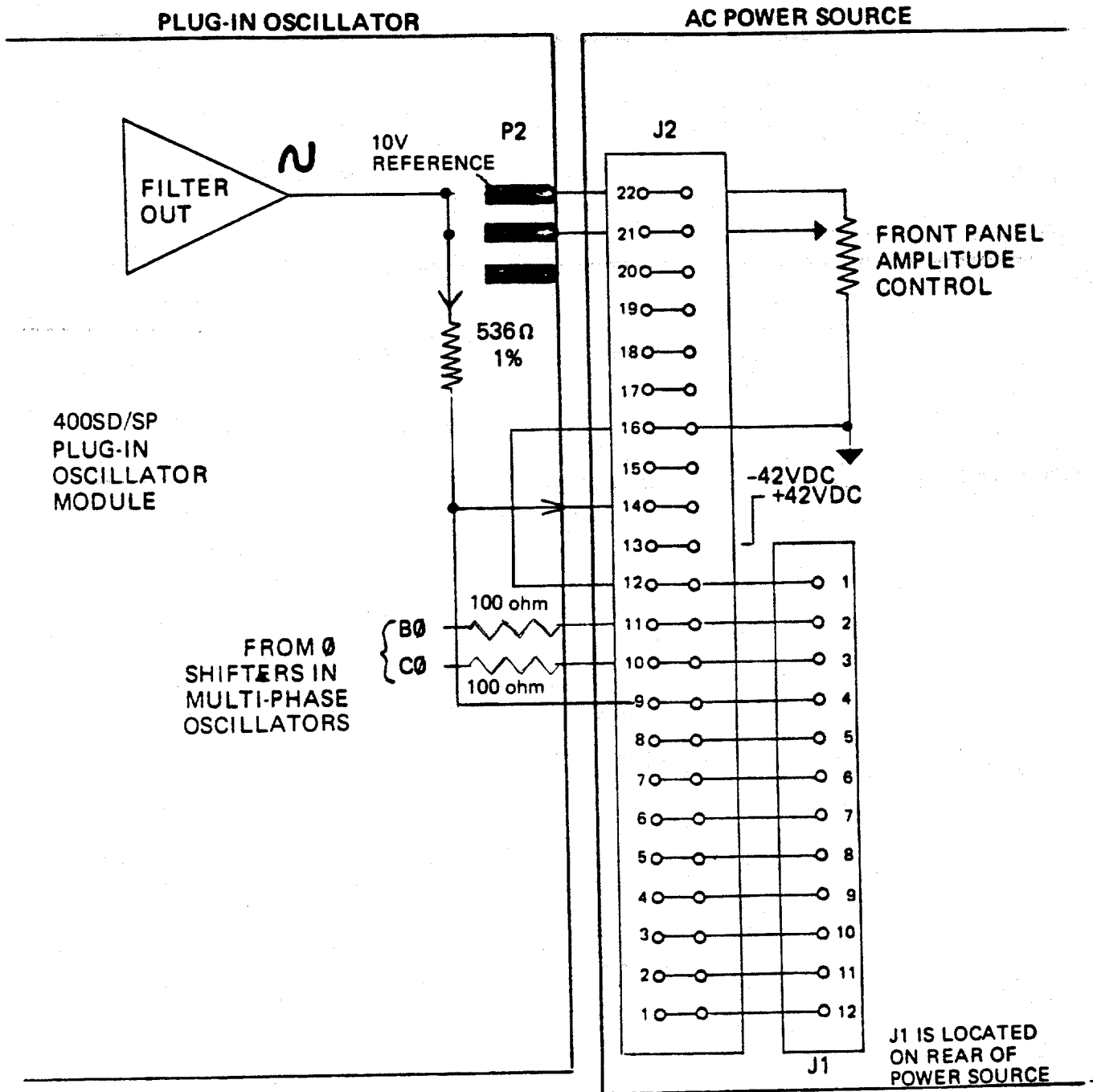

Figure 2-2. Typical Plug-in Oscillator/Power Source Interconnection

SECTION III THEORY OF OPERATION

3.1 OSCILLATOR CIRCUIT

3.1.1 The oscillator output contains 1024 bits or steps per cycle which have been synthesized from a fixed 10.24 MHz crystal oscillator. This gives a frequency accuracy of 0.001%.

3.1.2 The synthesis starts with the 10.24 MHz crystal oscillator which drives the Rate Multipliers U1, U2, U4 and U5. These rate multipliers will produce an output at U3B pin 8 which is proportional to the formula: Output equals crystal frequency divided by the quantity 10,000 multiplied by the BCD input from the switches. As an example: If the switches are set to 4000, the output at U3 pin 8 will be 4.096 MHz.

3.2.3 The frequency Range is controlled by U13A, U13B and S7. S7 allows direct through, divide by 10 or divide by 100 of the Rate Multiplier output. In the example of 4.096 MHz out of the Rate Multipliers, if we use the divide by 10 position of the switch S7, we will have 409.6 kHz to U10 pin 5.

3.1.4 Binary counters U10, U11 and U12 are up/down counters which are counting up only. U10 and U11 are counting by 256 for each quarter wave of the output signal and U12 is counting by 4 for each full cycle of the output frequency. This is a total count of 1024 per output cycle. Thus in the example the 409.6 kHz is counted to 400 Hz in the output.

3.1.5 The outputs of the binary counters are controlled by exclusive OR gates U6 and U7 which, when controlled by U12 pin 3, create the equivalent of an up/down drive to U9.

3.1.6 Integrated circuit U9 is a 256 by 8 Prom which has been programmed with a sine look-up table. When the address input lines are driven by U6 and U7, it will produce the digital output code for a sine table.

3.1.7 The digital outputs of the sine Prom drive multiplying digital to analog converter (DAC) U14. When U14 is thus driven, it will put out a current waveform which is proportional to the digital input multiplied by the reference current input through R52.

3.1.8 The current waveform out of DAC U14 is converted to a voltage waveform by amplifier A1B. This waveform will be a series of half wave, positive going signals. See timing diagram Figure 3-2 waveform B. This series of half wave signals is fed to amplifier A1A.

3.1.9 Amplifier A1A is an invert/noninvert amplifier with a gain of one. When enhancement mode FET Q3 has a positive on the gate, the source to drain resistance is very low. Thus if Q3 is on, pin 3 is shorted to common and the circuit is a normal inverting operational amplifier. Conversely, when Q3 is off, A1A will act as a non-inverting operational amplifier. Thus when waveform A of timing diagram (Figure 3-2) is applied to Q3 in synchronization with the analog signal of waveform B, the result will be the sine wave of waveform C on the output. This is filtered by the two pole filter of A2A and becomes the A phase output.

3.2 MULTI-PHASE OPTION

3.2.1 On the phase board, U1 is a Prom with a cosine look-up table. This is driven by the same address lines as is the sine prom of the basic oscillator. Thus the generation of the D phase, or -90° phase is done in the same manner as the A phase.

3.2.2 Differential amplifier A5B takes the difference of the -90° phase and the A phase and produces a B phase which is $+240$ degrees from the A phase.

3.2.3 Amplifier A6B takes the $+240^\circ$ B phase and the 0° A phase and produces the difference which is the C phase at $+120^\circ$.

3.3 FREQUENCY DETECTOR CIRCUIT (Model 400SD only)

3.3.1 Each half wave of the output frequency will cause U8 pin 6 to produce a narrow plus going spike. This will retrigger U15B which is a retriggerable monostable multivibrator. So long as the frequency is high enough, U15B will never time out. When the output frequency drops below 45 Hz, U15B will time out and U16B will clock in this information. When U16 is set, the front panel LED FREQUENCY LIMIT LIGHT will come on and the reference voltage will shut down which in turn shuts down the oscillator. When the frequency is selected back into limit, Q1 will turn off and the reference voltage will rise at the rate set by R14 and C8. This causes a soft-start of the power source.

3.3.2 The high frequency limit works in the opposite manner to the low frequency limit. Monostable multivibrator U15A must time out before the next pulse or the frequency is too high. If U15A has not timed out, the next pulse from U8 pin 6 will clock U16A and it will in turn, drive Q1 into the limit condition shutting down the oscillator output.

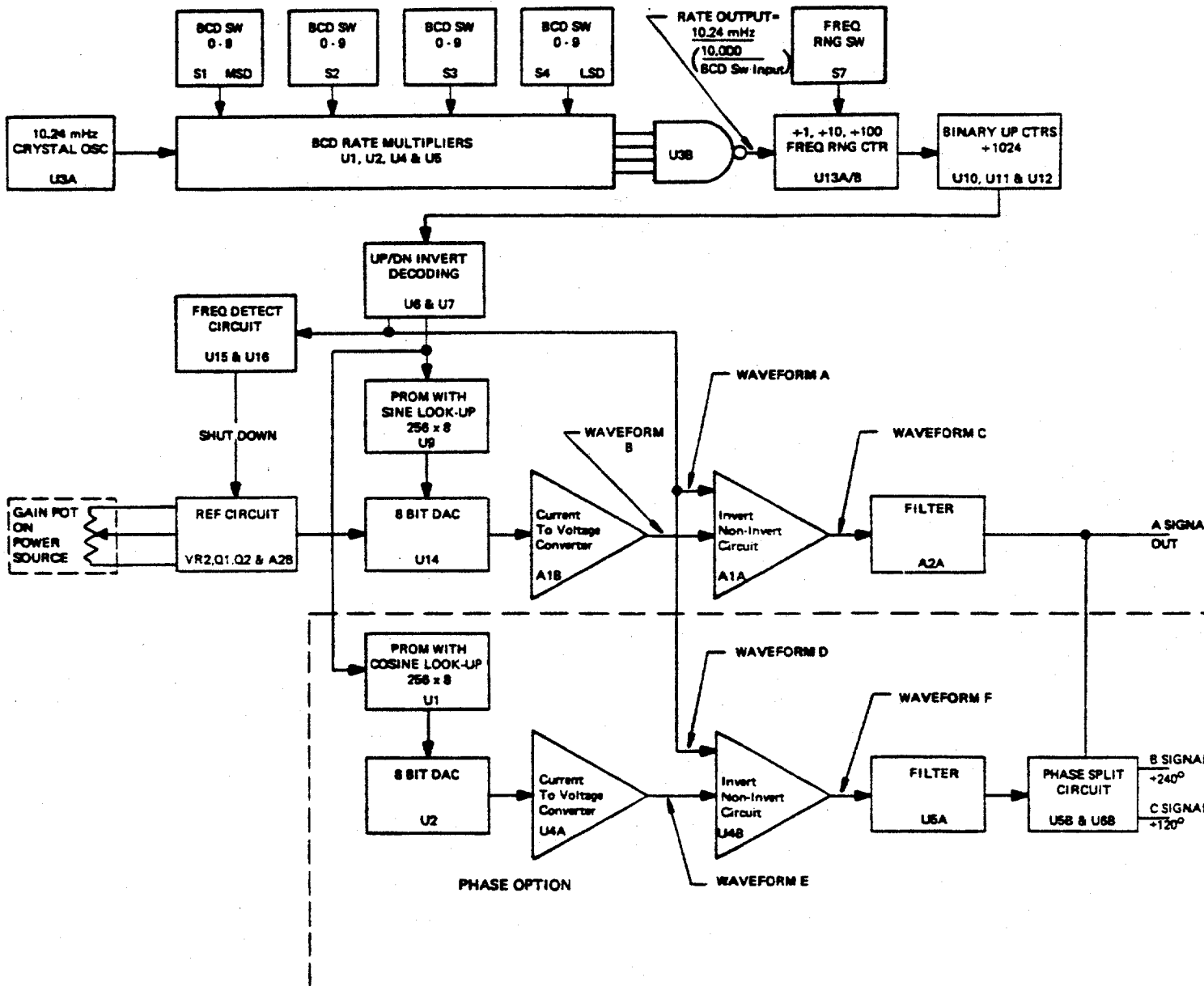

Figure 3-1. 400SD/SP Block Diagram

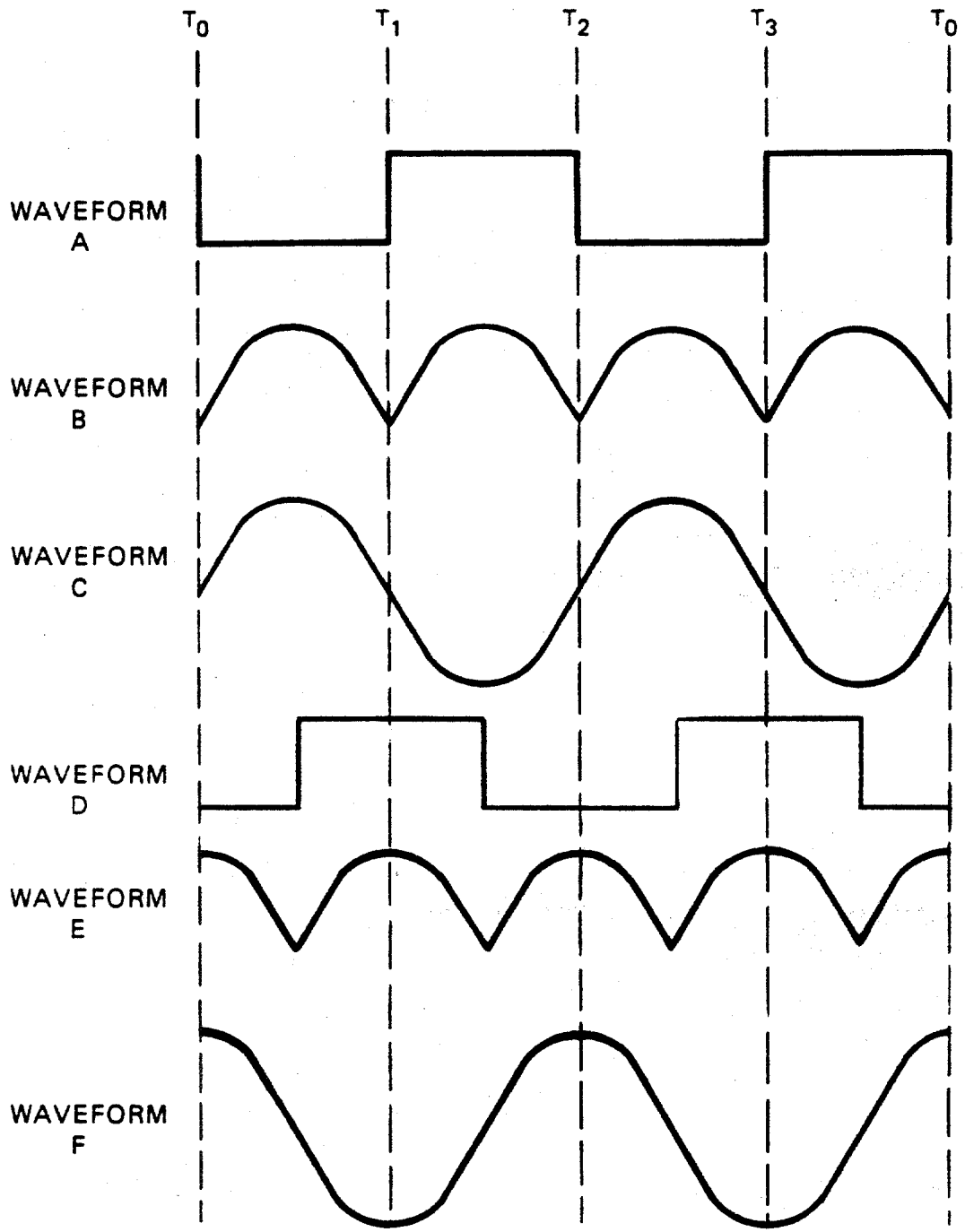

Figure 3-2. Timing Diagram

SECTION IV MAINTENANCE

4.1 SERVICE INFORMATION

4.1.1 Questions concerned with the operation, repair or servicing of this equipment should be directed to the Elgar Repair Department, Elgar 9250 Brown Deer Road, San Diego CA 92121-2294. Include model number and serial number in any correspondence concerning the instrument.

4.2 FACTORY SERVICE

4.2.1 Should it be necessary to return an instrument to the factory for repair, please contact the Elgar Repair Department for authorization to make shipment. **DO NOT RETURN THE UNIT FOR REPAIR WITHOUT AUTHORIZATION.**

4.3 SHIPPING DAMAGE

4.3.1 It is possible for equipment to be damaged in shipment. Therefore, it is imperative that the instrument be inspected and tested as soon as it is received. If the instrument shows signs of damage, notify the carrier immediately. The carrier's claim agent will prepare a report of damage to be forwarded to the Elgar Service Department. You will be advised as to the action necessary to have the instrument repaired or replaced.

4.4 SINGLE PHASE CALIBRATION

4.4.1 Single phase calibration for the 400SP is as follows:

1. Turn R10 fully counterclockwise and front panel Gain fully clockwise.
2. Turn S5-1 off and all other S5 and S6 switches on (sets 800 Hz).
3. Monitor A phase output with Distortion Analyzer (TP1).
4. Turn power on and adjust R10 so power source output is approximately 132V RMS.
5. Adjust R45 for minimum distortion output.
6. Adjust R51 for minimum distortion output.

4.4.2 Single phase calibration for the 400SD is as follows:

1. Turn R10 fully counterclockwise and front panel Gain fully clockwise.
2. Select 800 Hz on X10 range.
3. Monitor A phase output with Distortion Analyzer (TP1).
4. Turn on power and adjust R10 for approximately 132V RMS output.
5. Adjust R45 for minimum distortion output.
6. Adjust R51 for minimum distortion output.
7. Set oscillator to 45.00 on X1 range.
8. Turn R20 clockwise until front panel Freq Limit comes on, then turn counterclockwise until light just goes off.
9. Set Frequency to 51.00 on X100 range. Turn R17 counterclockwise until front panel Freq. Limit comes on, then turn clockwise until Freq Light just goes off.

4.5 PHASE BOARD CALIBRATION

4.5.1 Phase board calibration for the 400SD/SP is as follows:

1. Add phase board to tested 400SD/SP oscillator.
2. Set oscillator to 800 Hz and monitor phase board TP1 with Distortion Analyzer. Apply power.
3. Adjust R9 for minimum distortion output.
4. Adjust R10 for minimum distortion output.
5. Monitor main board TP1 with AC DMM and record reading (not required on recalibration).
6. Monitor phase board TP1 with AC DMM and adjust phase board R6 so reading is the same as recorded in previous step (not required on recalibration).
7. Set oscillator output frequency to 5 kHz (customer desired frequency in Model 400SP).
8. Connect phase angle meter with reference input to A phase TP1 and signal input to phase board TP1.
9. Adjust phase board C9 so phase angle is -90° ($+270^{\circ}$).

10. Reduce oscillator frequency to 50 Hz. (Leave Model 400SP at customer desired frequency.)
11. Move phase angle meter signal input to C phase output.
12. Adjust R6 for +120 phase angle.

4.6 RESISTANCE PROGRAMMING CALIBRATION

- 4.6.1 Connect a 13K ohm precision resistor between pins 7 and 8 of J1 on rear of power source. Turn on power.
- 4.6.2 Adjust locking Gain potentiometer on front panel of power source for 130V RMS output.
- 4.6.3 Change 13K ohm resistor to a 1K ohm resistor and adjust R8 on oscillator for 10V RMS output.
- 4.6.4 Repeat steps 4.6.1, 4.6.2 and 4.6.3 as required to compensate for interaction of adjustments. Set lock on power source front panel Gain.

4.7 VOLTAGE PROGRAMMING CALIBRATION

- 4.7.1 Apply +10VDC* to pin 6 with common to pin 1 of J1 on rear of power source. Turn on power.
- 4.7.2 Adjust locking Gain potentiometer on front panel of power source for 130V RMS output.
- 4.7.3 Reduce +10VDC* to +1VDC* and adjust R8 on oscillator for 13V RMS output.
- 4.7.4 Repeat steps 4.7.1, 4.7.2 and 4.7.3 as required to compensate for interaction. Set lock on power source front panel Gain.

*The voltage programming may be calibrated where +13VDC equals 130V RMS or where +10VDC equals 130V RMS output. This is customers option and is only where locking Gain potentiometer and R8 are set.

4.8 CIRCUIT BOARD COMPONENT LOCATION

- 4.8.1 Component location diagrams are given for the basic oscillator (Figure 5-1) and for the phase option (Figure 5-2). Those components in Figure 5-1 which are marked 6 are used in the model 400SD only.

4.9 TEST EQUIPMENT REQUIRED

Distortion Analyzer	Krohn-Hite 6800 or equal
Digital Voltmeter	Fluke 8050A or equal
Phase Angle Meter	Dytronics 224 or equal
Frequency Counter	Hewlett Packard 5307A or equal

SECTION V DIAGRAMS

5.1 GENERAL

5.1.1 This section contains the schematic diagrams for the Series 400SD/SP Plug-In Oscillators. The schematic diagrams should be used to understand the theory of operation and as an aid in troubleshooting the unit. Reference designators shown on schematics correspond to reference designators shown in parts lists where exact component values are given.

5.2 DIAGRAMS

5.2.1 Diagrams included in this section are as follows:

1. Schematic diagram for Model 400SD/SP main board.
2. Schematic diagram for Model 400SD/SP phase board.

5.2.2 The schematics in this section use \bigcirc to indicate P2 connections from the oscillator to J2 in the power source and \square to indicate an interconnection from the oscillator main board to the phase board.

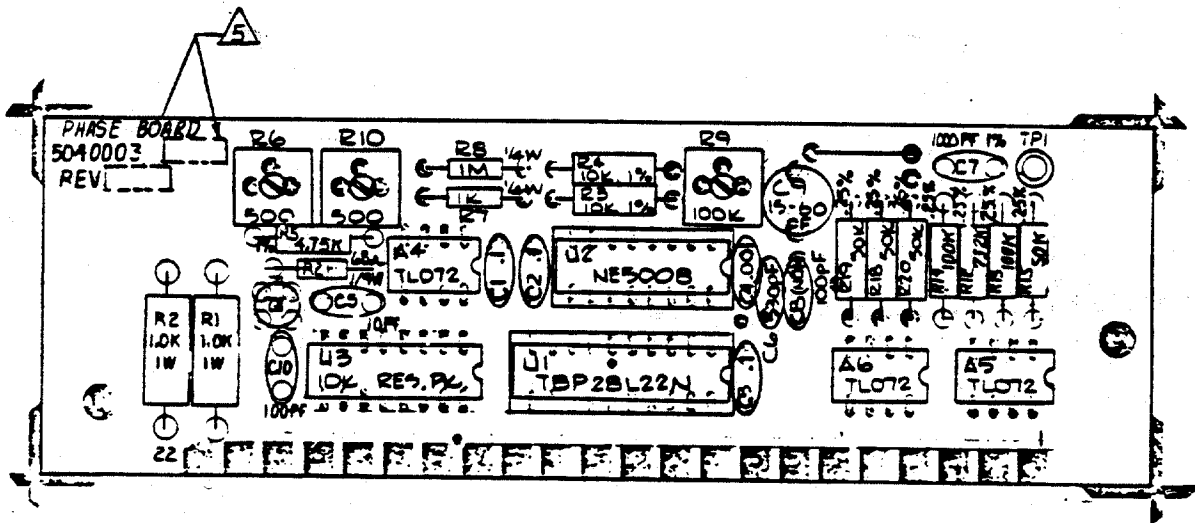

Figure 5-4. Model 400SD/SP Phase Board Assembly Drawing

SECTION VI REPAIR PARTS LIST

6.1 GENERAL

6.1.1 This section contains a listing of all parts necessary for factory authorized repair of the unit. Parts are located on the diagrams in Section V and correlated on the parts list by using their reference designators.

6.2 SPARE PARTS ORDERING

6.2.1 When ordering spare parts, specify part name, part number, manufacturer, component value and rating. If complete assemblies are desired, contact:

ELGAR
Repair Department
9250 Brown Deer Road
San Diego, CA 92121-2294
1-800-733-5427
Tel: (858) 450-0085
Fax: (858) 678-4482
www.elgar.com

Specify assembly number, instrument series number and instrument name when ordering.

SCHEMATIC DESIGNATION	VALUE	DESCRIPTION OR TYPE	RATING	MANUFACTURER		ELGAR PART NUMBER
				NAME	PART NUMBER	
C 23	10 pF	Cap Mica	5%	CDE	DM15-100J	820-100-05
C33	33 pF	Cap Mica	5%	CDE	DM15-330J	820-330-05
C30, 16, 18	47 pF	Cap Mica	5%	CDE	DM15-470J	820-470-05
C17	15-60 pF	Cap Var		Erie	538-011F 15-60	828-015-60
C11*, 32	.001 uF	Cap Disc		Centralab	DDM102	821-102-00
C19	.01 uF	Cap Disc		Centralab	DDM103	821-103-00
C2-4, 7-10, 24, 28, 29, 31	.1	Cap Disc	5%	Sprague	HY550	821-104-05
C20	1000 pF	Cap Mica	5%	CDE	DM15-102-J	820-102-05
C12*	.022 uF	Cap Mylar	5%			822-223-53
C13*	.22 uF	Cap Mylar	5%			822-224-53
C21, 15*	470 pF	Cap Mica	5%	CDE	DM15-471J	820-471-05
C1	470 uF	Cap Elect	16V	Sprague	501D478F016TV	824-478-01
C8, 14*, 35	10 uF	Cap Tant	20V	Sprague	196D106X0020JA1	834-106-41
C5, 6	100 uF	Cap Elect	50V	Sprague	500D107G050DH7	824-107-71
CR6, 7		Diode		IN914	IN914	844-914-XX
CR1, 2, 8, 5		Diode		IN4004	IN4004	845-400-4X
CR3, 4		Diode		IN4749A	IN4749A	843-474-9A
U3		Dual NAND		TI	SN74LS20N	849-LS2-OX
U16*		Dual D F/F		TI	SN74LS74N	849-LS8-4X
U6, 7, 8		Quad EX OR		TI	SN74LS86N	849-LS8-6X
U15*		Dual Timer		TI	SN74LS123N	849-LS1-23
U1, 2, 4, 5		Rate Mult		TI	SN74167N	849-741-67
U10, 11, 12		Bin Ctr		TI	SN74LS193N	849-LS1-93
U13		Dual Ctr		TI	SN74LS390N	849-LS3-90
A1, 2		Dual Op-Amp		TI	TL072CP	849-TL0-72
U14		8 BIT DAC		Signetics	NE5008N	849-N50-08
*Not applicable to 400SP. #		Not applicable to 400SD.				
K1	6V Coil	Relay	3 Pole	Douglas Randall	6MG 3A	861-6MG-3A
Q5		Transistor NPN		Motorola	MPSA13	833-MP8-III

SCHEMATIC DESIGNATION	VALUE	DESCRIPTION OR TYPE	RATING	MANUFACTURER		ELGAR PART NUMBER
				NAME	PART NUMBER	
U9		Sine Prom		Elgar		849-SA2-5D
VR2		T092 Reg	+10V	T1	UA78L10ACP	849-78L-10
VR3		T092 Reg	+15V	T1	UA78L15ACP	849-78L-15
VR4		T092 Reg	-15V	National	LM320L2	849-LM3-20
DS1*		Red LED		H.P.	5082-4655	848-655-02
Q1, Q2*		Transistor, NPN		Signetics	2N3568	835-356-8X
Q3		Transistor, FET			SD213DE	842-SD2-13
Q4		Transistor			2N3643	835-364-3X
R23*, 24*	510	Res 1W	5%	Allen-Bradley	RC07GF511J	801-511-05
R21*	3.3M	Res 1W	5%	Allen-Bradley	RC07GF335J	801-335-05
R9, 25, 26, 49, 58	1K	Res 1W	5%	Allen-Bradley	RC07GF102J	801-102-05
R33	680	Res 1W	5%	Allen-Bradley	RC07GF681J	801-681-05
R22*, 34, 47	10K	Res 1W	5%	Allen-Bradley	RC07GF103J	801-103-05
R14*, 61	47K	Res 1W	5%	Allen-Bradley	RC07GF473J	801-473-05
R13*, 15*, 55*	3.9K	Res 1W	5%	Allen-Bradley	RC07GF392J	801-392-05
R7, 16*, 50	1M	Res 1W	5%	Allen-Bradley	RC07GF105J	801-105-05
R18*	7.5K	Res 1/8W	1%	Bradley	RN60C7501F	813-750-1F
R11, 12	13K	Res 1/8W	1%	Dale	RN60C1302F	813-130-2F
R19*	90.9K	Res 1/8W	1%	Dale	RN60C9092F	813-909-2F
R54	475 ohm	Res 1/8W	1%	Dale	RN60C4750F	813-475-0F
R56, 57	100	Res 1/8W	1%	Dale	RN60C1000F	813-100-0F
R48	4.99K	Res 1/8W	1%	Dale	RN60C4991F	813-499-1F
R52, 53	10K	Res 1/8W	1%	Dale	RN60C1002F	813-100-2F
R2	1K	Res 1W	5%	Allen-Bradley	RC32GF102J	803-102-05
R1	680	Res 2W	5%	Allen-Bradley	RC42GF681J	804-681-05
R10, 17*	20K	POT 1T		Bradley	63P503	819-203-63
R8, 20*, 51	100K	POT 1T		Spectrol	63P104	819-104-63

SCHEMATIC DESIGNATION	VALUE	DESCRIPTION OR TYPE	RATING	MANUFACTURER		ELGAR PART NUMBER
				NAME	PART NUMBER	
R45	500	POT 1T		Spectrol	63P501	819-501-63
R59,60	2.2K	Resistor	1W, 5%	Allen	RC07GF222J	801-222-05
R60	22K	Resistor	1W, 5%	Bradley	RC07GF223J	801-223-05
R19A (option)	383K	Resistor	1/8W, 1%	Dale	RN60C3833F	813-383-3F
RP1,2	10K	9 Res DIP	5%	Beckman	785-1-R10K	818-103-5P
RP3	10K	8 Res DIP	1%	Beckman	698-3-R10KF	818-103-DR
S1-4*		BCD SW		Std	14895MP/	860-BCD-09
S7*		1 Pole 3T Roty		Grigsby	REL-10-1	
S5,6#		8 Pos DIP SW		Centralab	1461	860-146-1X
T1		Transformer	16V	CTS	206-8	860-206-8X
Y1	10.24 MHz	Crystal		Signal Monitor	ST4-16 MC18A-32-10.24 MHz	850-ST4-16 864-102-4X

5040003 400SD/SP PHASE BOARD

SCHEMATIC DESIGNATION	VALUE	DESCRIPTION OR TYPE	RATING	MANUFACTURER		ELGAR PART NUMBER
				NAME	PART NUMBER	
C5	10 pF	Cap Mica	5%	CDE	DM15-100J	820-100-05
C8,10	100 pF	Cap Mica	5%	CDE	DM15-101J	820-101-05
C7	1000 pF	Cap Mica	5%	CDE	DM15-102J	820-102-05
C6	330 pF	Cap Mica	5%	CDE	DM15-331J	820-331-05
C4	.001	Cap Disc		Centralab	DDM102	821-102-00
C1,2,3	.1	Cap Disc		Sprague	HY550	821-104-05
Q1		Transistor FET		Signetics	SD213DE	842-SD2-13
R7	1K	Res 1/8W	5%	Allen-	RC07GF102J	801-102-05
R8	1M	Res 1/8W	5%	Bradley	RC07GF105J	801-105-05
R21	68	Res 1/8W	5%	Allen-	RC07GF680J	801-680-05
R1,2	1K	Res 1W	5%	Bradley	RC32GF102J	803-102-05
R5	4.75K	Res 1/8W	1%	Dale	RN60C4751F	813-475-1F
R3,4	10K	Res 1/8W	1%	Dale	RN60C1002F	813-100-2F
R15,18,19,20	50K	Res 1/8W	.25%	Dale	RN60C5002C	814-500-2C
R12	73.2K	Res 1/8W	.25%	Dale	RN60C7322C	814-732-2C
R13,14	100K	Res 1/8W	.25%	Dale	RN60C1003C	814-100-3C
R6,10	500	POT 1T		Spectrol	63P501	819-501-63
R9	100K	POT 1T		Spectrol	63P104	819-104-63
U1		Cosine Prom		Elgar	NE5008N	849-CA2-5D
U2		8 BIT DAC		Signetics	698-3-R10KF	849-N50-08
U3	10K	8 Res DIP		Beckman	TL072CP	818-103-DR
A4,5,6		Dual OP-AMP		TI		849-TL0-72

CLASS CODE GROUP: 1 COMMODITY CLASS
 CLASS CODE: 120 ASSEMBLY, ELGAR - CABLE/HARNES

5040004-01 OPCODE: 3 REV: E SERVO BDASY400SD/SP3 S

MODEL: OP: ORDER POLICY CODE
 ECO NO: REQ:N=PART OPTIONAL
 DATE OF LAST ECO: 00/00/00 PF: N=PART DOES NOT PRINT ON SALES ORDER
 Y=PART PRINTS ON SALES ORDER W/O PRICE
 P=PART PRINTS ON SALES ORDER WITH PRICE

PART NUMBER	DESCRIPTION	O P RV	ITEM NO.	QTY PER ASSEMBLY	YIELD FACTR	UM	SC	R EP QF	PREP CODE	DAYS OFF SET	SEQ	DESIGNATOR	EFFECTIVE DATE	OBSOLETE DATE
813-249-1F	RES, 2.49K, 1/4W, 1%, 70C, RN60, MF	3	E	3.000	1.000	EA	B	YN	3.000	0	0	R35,36,37	00/00/00	99/99/99
2040004-01	A/W SERVO BD S	3	F	1.000	1.000	EA	B	YN	.000	0	0		00/00/00	99/99/99
9040004-01	PCB SERVO BD 400SD/SP S	3	F	1.000	1.000	EA	B	YN	1.000	0	0		00/00/00	99/99/99
6040004-01	SCHEMATIC SERVO BD S	3	D	2.000	1.000	EA	B	YN	.000	0	0		00/00/00	99/99/99
823-105-61	CAP, 1UF, 35V, 20%, TANT	3	E	2.000	1.000	EA	B	YN	2.000	0	0	C6,7	00/00/00	99/99/99
823-474-61	CAP, .47UF, 35V, 20%, TANT	3	G	3.000	1.000	EA	B	YN	3.000	0	0	C1-3	00/00/00	99/99/99
824-477-61	CAP, 470UF, 35V, AL, AXL	3	B	2.000	1.000	EA	B	YN	2.000	0	0	C4,5	00/00/00	99/99/99
848-LM3-29	DIODE, REFERENCE, 6.9V	3	B	1.000	1.000	EA	B	YN	1.000	0	0	CR1	00/00/00	99/99/99
843-474-4A	DIODE, ZENER, 15V, 1W, 5%	3	B	4.000	1.000	EA	B	YN	4.000	0	0	CR11-14	00/00/00	99/99/99
844-914-XX	DIODE, SIGNAL, 100V, SWITCH	3	D	9.000	1.000	EA	F	YN	9.000	0	0	CR2-10	00/00/00	99/99/99
818-103-DR	RESNET, 10K, 1%, 16P, 8RES, DIP	3	C	3.000	1.000	EA	B	YN	3.000	0	0	U7-9	00/00/00	99/99/99
819-202-64	POT, 2.0K, 1/2W, 25T, PC	3	B	2.000	1.000	EA	B	YN	2.000	0	0	R19,28	00/00/00	99/99/99
819-502-64	POT, 5.0K, 1/2W, 16T, PCM, VERT	3	C	3.000	1.000	EA	B	YN	3.000	0	0	R11,20,29	00/00/00	99/99/99
819-501-99	POT, 500, 1/2W, 25T, PC	3	B	3.000	1.000	EA	B	YN	3.000	0	0	R9,18,27	00/00/00	99/99/99
804-561-05	RES, 560, 2W, 5%	3	B	2.000	1.000	EA	B	YN	2.000	0	0	R33,34	00/00/00	99/99/99
813-255-1F	RES, 2.55K, 1/4W, 1%, 70C, RN60, MF	3	B	1.000	1.000	EA	B	YN	1.000	0	0	R3	00/00/00	99/99/99
818-287-1E	RES, 2.87K, 1/8W, 1%, 25PPM	3	B	1.000	1.000	EA	B	YN	1.000	0	0	R5	00/00/00	99/99/99
818-649-1E	RES, 6.49K, 1/8W, 1%, 25PPM	3	B	1.000	1.000	EA	B	YN	1.000	0	0	R4	00/00/00	99/99/99
818-976-1E	RES, 9.76K, 1/8W, 1%, 25PPM	3	B	3.000	1.000	EA	B	YN	3.000	0	0	R8,17,26	00/00/00	99/99/99
813-100-1F	RES, 1.00K, 1/4W, 1%, 70C, RN60, MF	3	B	1.000	1.000	EA	B	YN	1.000	0	0	R10	00/00/00	99/99/99
813-100-2F	RES, 10.0K, 1/4W, 1%, 70C, RN60, MF	3	B	2.000	1.000	EA	B	YN	2.000	0	0	R1,2	00/00/00	99/99/99
801-153-05	RES, 15K, 1/4W, 2%, MF	3	B	3.000	1.000	EA	B	YN	3.000	0	0	R13,22,31	00/00/00	99/99/99
801-101-05	RES, 100, 1/4W, 2%, MF	3	B	3.000	1.000	EA	F	YN	3.000	0	0	R14,23,32	00/00/00	99/99/99
801-392-05	RES, 3.9K, 1/4W, 2%, MF	3	B	3.000	1.000	EA	B	YN	3.000	0	0	R12,21,30	00/00/00	99/99/99
818-390-3E	RES, 390K, 1/4W, 1%, 25PPM	3	B	6.000	1.000	EA	B	YN	6.000	0	0	R6,7,15,16,24,25	00/00/00	99/99/99
849-TL0-72	IC, LIN, TL072CP, 2XFET, OP AMP	3	B	7.000	1.000	EA	B	YN	7.000	0	0	U2,4,6,10-13	00/00/00	99/99/99
849-VTL-2C	IC, OPTO, PHOTO RES, LED	3	A	3.000	1.000	EA	B	YN	3.000	0	0	U1,3,5	00/00/00	99/99/99
849-781-5P	IC, REG, VOLT, 7815ACP, 15V	3	D	1.000	1.000	EA	B	YN	1.000	0	0	VR1	00/00/00	99/99/99
849-791-5P	IC, REG, VOLT, NEG, 15V	3	C	1.000	1.000	EA	B	YN	1.000	0	0	VR2	00/00/00	99/99/99
109-157-0A	SPACER, SWG, #6 X .375L, .25RD	3		3.000	1.000	EA	B	YN	3.000	0	0		00/00/00	99/99/99
110CA00-04	SCREW, USE 110CA04-04	3		2.000	1.000	EA	F	YN	2.000	0	0		00/00/00	99/99/99
111CC04-01	WASHER, 4, SPLIT LOCK	3		2.000	1.000	EA	F	YN	2.000	0	0		00/00/00	99/99/99
112CB04-01	NUT, 4-40, HEX, STD, CS	3		2.000	1.000	EA	F	YN	2.000	0	0		12/02/96	99/99/99
109-771-73	INSUL, MTG PAD, TO-5/TO-39, NYL	3	C	3.000	1.000	EA	B	YN	3.000	0	0	PAD U1,3,5	00/00/00	99/99/99

LI, 200, 2. MDATA01 ELGAR CORPORATION
FRI, OCT 22, 1999, 1:02 PM

DISTRIBUTION: DEBBIEF -
BILL OF MATERIAL
=====

PAGE NO: 1

CLASS CODE GROUP: 1 COMMODITY CLASS
CLASS CODE: 180 ASSEMBLY, ELGAR - PCB

5040004-02 OPCODE: 3 REV: F SERVO BDASY400SD/SP1 S
MODEL: 400SD/SP
ECO NO: N970788
DATE OF LAST ECO: 08/12/97

OP: ORDER POLICY CODE
REQ:N=PART OPTIONAL
Y=PART REQUIRED
PF: N=PART DOES NOT PRINT ON SALES ORDER
Y=PART PRINTS ON SALES ORDER W/O PRICE
P=PART PRINTS ON SALES ORDER WITH PRICE

PART NUMBER	DESCRIPTION	O P R V	ITEM NO.	QTY PER ASSEMBLY	YIELD FACTR	UM	SC	EP	QF	R	PREP CODE	DAYS OFF SET	SEQ	DESIGNATOR	EFFECTIVE DATE	OBSOLETE DATE
813-249-1F	RES, 2.49K, 1/4W, 1%, 70C, RN60, MF	3	0	1.000	1.000	EA	B	Y	N		1.000	0	0	R37	00/00/00	99/99/99
2040004-01	A/W SERVO BD	3	E	4	1.000	EA	B	Y	N		1.000	0	0		12/02/96	99/99/99
9040004-01	PCB SERVO BD 400SD/SP S	3	F	5	1.000	EA	B	Y	N		1.000	0	0		00/00/00	99/99/99
6040004-01	SCHEMATIC SERVO BD S	3	D	6	1.000	EA	B	Y	N		1.000	0	0		12/02/96	99/99/99
823-105-61	CAP, 1UF, 35V, 20%, TANT	3	D	9	2.000	EA	B	Y	N		2.000	0	0		00/00/00	99/99/99
823-474-61	CAP, .47UF, 35V, 20%, TANT	3	E	10	1.000	EA	B	Y	N		1.000	0	0	C6,7	00/00/00	99/99/99
824-477-61	CAP, 470UF, 35V, AL, AXL	3	G	11	2.000	EA	B	Y	N		2.000	0	0	C1-3	00/00/00	99/99/99
848-LM3-29	DIODE, REFERENCE, 6.9V	3	B	13	1.000	EA	B	Y	N		1.000	0	0	C4,5	00/00/00	99/99/99
843-474-4A	DIODE, ZENER, 15V, 1W, 5%	3	B	14	4.000	EA	B	Y	N		4.000	0	0	CR1	00/00/00	99/99/99
844-914-XX	DIODE, SIGNAL, 100V, SWITCH	3	D	15	3.000	EA	F	Y	N		3.000	0	0	CR11-14	00/00/00	99/99/99
818-103-DR	RESNET, 10K, 1%, 16P, 8RES, DIP	3	C	17	1.000	EA	B	Y	N		1.000	0	0	U9	08/12/97	99/99/99
819-502-64	POT, 5.0K, 1/2W, 16T, PCM, VERT	3	C	19	1.000	EA	B	Y	N		1.000	0	0	CR2-4	08/12/97	99/99/99
819-501-99	POT, 500, 1/2W, 25T, PC	3	3	20	1.000	EA	B	Y	N		1.000	0	0	R11	08/12/97	99/99/99
804-102-05	RES, 1K, 2W, 5%	3	21	2.000	1.000	EA	B	Y	N		2.000	0	0	R9	08/12/97	99/99/99
813-255-1F	RES, 2.55K, 1/4W, 1%, 70C, RN60, MF	3	23	1.000	1.000	EA	B	Y	N		1.000	0	0	R33,34	00/00/00	99/99/99
818-287-1E	RES, 2.87K, 1/8W, 1%, 25PPM	3	24	1.000	1.000	EA	B	Y	N		1.000	0	0	R3	00/00/00	99/99/99
818-649-1E	RES, 6.49K, 1/8W, 1%, 25PPM	3	25	1.000	1.000	EA	B	Y	N		1.000	0	0	R5	00/00/00	99/99/99
818-976-1E	RES, 9.76K, 1/8W, 1%, 25PPM	3	26	1.000	1.000	EA	B	Y	N		1.000	0	0	R4	00/00/00	99/99/99
813-100-1F	RES, 1.00K, 1/4W, 1%, 70C, RN60, MF	3	28	1.000	1.000	EA	B	Y	N		1.000	0	0	R8	08/12/97	99/99/99
813-100-2F	RES, 10.0K, 1/4W, 1%, 70C, RN60, MF	3	29	2.000	1.000	EA	B	Y	N		2.000	0	0	R10	00/00/00	99/99/99
801-153-05	RES, 15K, 1/4W, 2%, MF	3	30	1.000	1.000	EA	B	Y	N		1.000	0	0	R1,2	00/00/00	99/99/99
801-101-05	RES, 100, 1/4W, 2%, MF	3	31	1.000	1.000	EA	F	Y	N		1.000	0	0	R13	08/12/97	99/99/99
801-392-05	RES, 3.9K, 1/4W, 2%, MF	3	32	1.000	1.000	EA	B	Y	N		1.000	0	0	R14	08/12/97	99/99/99
818-390-3E	RES, 390K, 1/4W, 1%, 25PPM	3	33	2.000	1.000	EA	B	Y	N		2.000	0	0	R12	08/12/97	99/99/99
849-TL0-72	IC, LIN, TL072CP, 2XFET, OP AMP	3	B	35	5.000	EA	B	Y	N		5.000	0	0	U2,4,6,10,13	08/12/97	99/99/99
849-VTL-2C	IC, OPTO, PHOTO RES, LED	3	A	36	1.000	EA	B	Y	N		1.000	0	0	U5	00/00/00	99/99/99
849-781-5P	IC, REG, VOLT, 7815ACP, 15V	3	D	37	1.000	EA	B	Y	N		1.000	0	0	VR1	00/00/00	99/99/99
849-791-5P	IC, REG, VOLT, NEG, 15V	3	C	38	1.000	EA	B	Y	N		1.000	0	0	VR2	00/00/00	99/99/99
109-157-0A	SPACER, SWG, #6 X .375L, .25RD	3	40	3.000	1.000	EA	B	Y	N		3.000	0	0		00/00/00	99/99/99
110CA00-04	SCREW, USE 110CA04-04	3	51	2.000	1.000	EA	F	Y	N		2.000	0	0		00/00/00	99/99/99
111CC04-01	WASHER, 4, SPLIT LOCK	3	52	2.000	1.000	EA	F	Y	N		2.000	0	0		00/00/00	99/99/99
112CR04-01	NUT, 4-40, HEX, STD, CS	3	53	2.000	1.000	EA	F	Y	N		2.000	0	0		12/02/96	99/99/99

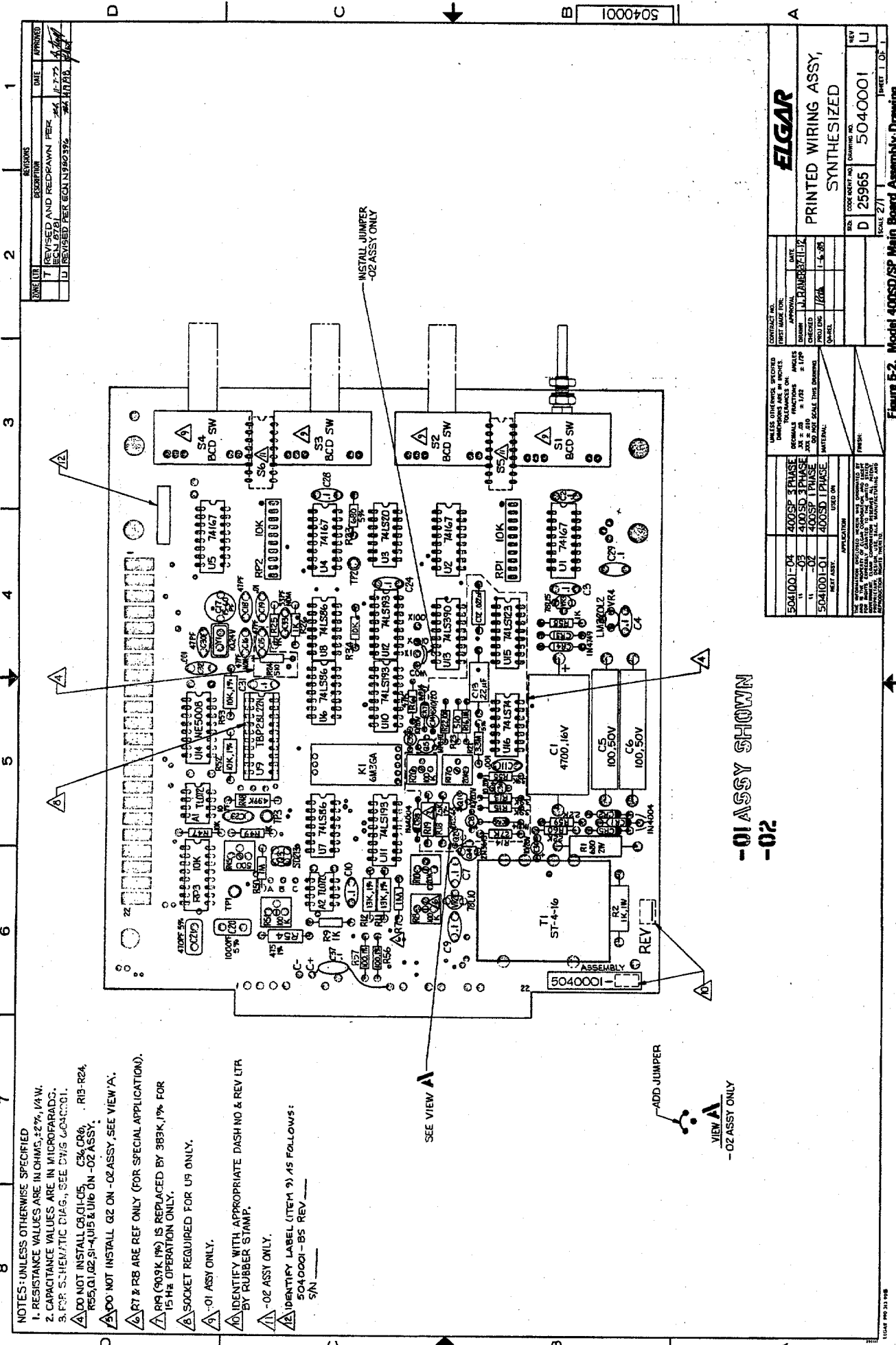

NOTES: UNLESS OTHERWISE SPECIFIED
 1. RESISTANCE VALUES ARE IN OHMS, 27%, 1/4 W.
 2. CAPACITANCE VALUES ARE IN MICROFARADS.
 3. FOR SCHEMATIC DIAG., SEE DWS 404C001.
 4. DO NOT INSTALL CR1, CR2, CR3, CR4, CR5, CR6, CR7, CR8, CR9, CR10, CR11, CR12, CR13, CR14, CR15, CR16, CR17, CR18, CR19, CR20, CR21, CR22, CR23, CR24, CR25, CR26, CR27, CR28, CR29, CR30, CR31, CR32, CR33, CR34, CR35, CR36, CR37, CR38, CR39, CR40, CR41, CR42, CR43, CR44, CR45, CR46, CR47, CR48, CR49, CR50, CR51, CR52, CR53, CR54, CR55, CR56, CR57, CR58, CR59, CR60, CR61, CR62, CR63, CR64, CR65, CR66, CR67, CR68, CR69, CR70, CR71, CR72, CR73, CR74, CR75, CR76, CR77, CR78, CR79, CR80, CR81, CR82, CR83, CR84, CR85, CR86, CR87, CR88, CR89, CR90, CR91, CR92, CR93, CR94, CR95, CR96, CR97, CR98, CR99, CR100, CR101, CR102, CR103, CR104, CR105, CR106, CR107, CR108, CR109, CR110, CR111, CR112, CR113, CR114, CR115, CR116, CR117, CR118, CR119, CR120, CR121, CR122, CR123, CR124, CR125, CR126, CR127, CR128, CR129, CR130, CR131, CR132, CR133, CR134, CR135, CR136, CR137, CR138, CR139, CR140, CR141, CR142, CR143, CR144, CR145, CR146, CR147, CR148, CR149, CR150, CR151, CR152, CR153, CR154, CR155, CR156, CR157, CR158, CR159, CR160, CR161, CR162, CR163, CR164, CR165, CR166, CR167, CR168, CR169, CR170, CR171, CR172, CR173, CR174, CR175, CR176, CR177, CR178, CR179, CR180, CR181, CR182, CR183, CR184, CR185, CR186, CR187, CR188, CR189, CR190, CR191, CR192, CR193, CR194, CR195, CR196, CR197, CR198, CR199, CR200, CR201, CR202, CR203, CR204, CR205, CR206, CR207, CR208, CR209, CR210, CR211, CR212, CR213, CR214, CR215, CR216, CR217, CR218, CR219, CR220, CR221, CR222, CR223, CR224, CR225, CR226, CR227, CR228, CR229, CR230, CR231, CR232, CR233, CR234, CR235, CR236, CR237, CR238, CR239, CR240, CR241, CR242, CR243, CR244, CR245, CR246, CR247, CR248, CR249, CR250, CR251, CR252, CR253, CR254, CR255, CR256, CR257, CR258, CR259, CR260, CR261, CR262, CR263, CR264, CR265, CR266, CR267, CR268, CR269, CR270, CR271, CR272, CR273, CR274, CR275, CR276, CR277, CR278, CR279, CR280, CR281, CR282, CR283, CR284, CR285, CR286, CR287, CR288, CR289, CR290, CR291, CR292, CR293, CR294, CR295, CR296, CR297, CR298, CR299, CR300, CR301, CR302, CR303, CR304, CR305, CR306, CR307, CR308, CR309, CR310, CR311, CR312, CR313, CR314, CR315, CR316, CR317, CR318, CR319, CR320, CR321, CR322, CR323, CR324, CR325, CR326, CR327, CR328, CR329, CR330, CR331, CR332, CR333, CR334, CR335, CR336, CR337, CR338, CR339, CR340, CR341, CR342, CR343, CR344, CR345, CR346, CR347, CR348, CR349, CR350, CR351, CR352, CR353, CR354, CR355, CR356, CR357, CR358, CR359, CR360, CR361, CR362, CR363, CR364, CR365, CR366, CR367, CR368, CR369, CR370, CR371, CR372, CR373, CR374, CR375, CR376, CR377, CR378, CR379, CR380, CR381, CR382, CR383, CR384, CR385, CR386, CR387, CR388, CR389, CR390, CR391, CR392, CR393, CR394, CR395, CR396, CR397, CR398, CR399, CR400, CR401, CR402, CR403, CR404, CR405, CR406, CR407, CR408, CR409, CR410, CR411, CR412, CR413, CR414, CR415, CR416, CR417, CR418, CR419, CR420, CR421, CR422, CR423, CR424, CR425, CR426, CR427, CR428, CR429, CR430, CR431, CR432, CR433, CR434, CR435, CR436, CR437, CR438, CR439, CR440, CR441, CR442, CR443, CR444, CR445, CR446, CR447, CR448, CR449, CR450, CR451, CR452, CR453, CR454, CR455, CR456, CR457, CR458, CR459, CR460, CR461, CR462, CR463, CR464, CR465, CR466, CR467, CR468, CR469, CR470, CR471, CR472, CR473, CR474, CR475, CR476, CR477, CR478, CR479, CR480, CR481, CR482, CR483, CR484, CR485, CR486, CR487, CR488, CR489, CR490, CR491, CR492, CR493, CR494, CR495, CR496, CR497, CR498, CR499, CR500, CR501, CR502, CR503, CR504, CR505, CR506, CR507, CR508, CR509, CR510, CR511, CR512, CR513, CR514, CR515, CR516, CR517, CR518, CR519, CR520, CR521, CR522, CR523, CR524, CR525, CR526, CR527, CR528, CR529, CR530, CR531, CR532, CR533, CR534, CR535, CR536, CR537, CR538, CR539, CR540, CR541, CR542, CR543, CR544, CR545, CR546, CR547, CR548, CR549, CR550, CR551, CR552, CR553, CR554, CR555, CR556, CR557, CR558, CR559, CR560, CR561, CR562, CR563, CR564, CR565, CR566, CR567, CR568, CR569, CR570, CR571, CR572, CR573, CR574, CR575, CR576, CR577, CR578, CR579, CR580, CR581, CR582, CR583, CR584, CR585, CR586, CR587, CR588, CR589, CR590, CR591, CR592, CR593, CR594, CR595, CR596, CR597, CR598, CR599, CR600, CR601, CR602, CR603, CR604, CR605, CR606, CR607, CR608, CR609, CR610, CR611, CR612, CR613, CR614, CR615, CR616, CR617, CR618, CR619, CR620, CR621, CR622, CR623, CR624, CR625, CR626, CR627, CR628, CR629, CR630, CR631, CR632, CR633, CR634, CR635, CR636, CR637, CR638, CR639, CR640, CR641, CR642, CR643, CR644, CR645, CR646, CR647, CR648, CR649, CR650, CR651, CR652, CR653, CR654, CR655, CR656, CR657, CR658, CR659, CR660, CR661, CR662, CR663, CR664, CR665, CR666, CR667, CR668, CR669, CR670, CR671, CR672, CR673, CR674, CR675, CR676, CR677, CR678, CR679, CR680, CR681, CR682, CR683, CR684, CR685, CR686, CR687, CR688, CR689, CR690, CR691, CR692, CR693, CR694, CR695, CR696, CR697, CR698, CR699, CR700, CR701, CR702, CR703, CR704, CR705, CR706, CR707, CR708, CR709, CR710, CR711, CR712, CR713, CR714, CR715, CR716, CR717, CR718, CR719, CR720, CR721, CR722, CR723, CR724, CR725, CR726, CR727, CR728, CR729, CR730, CR731, CR732, CR733, CR734, CR735, CR736, CR737, CR738, CR739, CR740, CR741, CR742, CR743, CR744, CR745, CR746, CR747, CR748, CR749, CR750, CR751, CR752, CR753, CR754, CR755, CR756, CR757, CR758, CR759, CR760, CR761, CR762, CR763, CR764, CR765, CR766, CR767, CR768, CR769, CR770, CR771, CR772, CR773, CR774, CR775, CR776, CR777, CR778, CR779, CR780, CR781, CR782, CR783, CR784, CR785, CR786, CR787, CR788, CR789, CR790, CR791, CR792, CR793, CR794, CR795, CR796, CR797, CR798, CR799, CR800, CR801, CR802, CR803, CR804, CR805, CR806, CR807, CR808, CR809, CR810, CR811, CR812, CR813, CR814, CR815, CR816, CR817, CR818, CR819, CR820, CR821, CR822, CR823, CR824, CR825, CR826, CR827, CR828, CR829, CR830, CR831, CR832, CR833, CR834, CR835, CR836, CR837, CR838, CR839, CR840, CR841, CR842, CR843, CR844, CR845, CR846, CR847, CR848, CR849, CR850, CR851, CR852, CR853, CR854, CR855, CR856, CR857, CR858, CR859, CR860, CR861, CR862, CR863, CR864, CR865, CR866, CR867, CR868, CR869, CR870, CR871, CR872, CR873, CR874, CR875, CR876, CR877, CR878, CR879, CR880, CR881, CR882, CR883, CR884, CR885, CR886, CR887, CR888, CR889, CR890, CR891, CR892, CR893, CR894, CR895, CR896, CR897, CR898, CR899, CR900, CR901, CR902, CR903, CR904, CR905, CR906, CR907, CR908, CR909, CR910, CR911, CR912, CR913, CR914, CR915, CR916, CR917, CR918, CR919, CR920, CR921, CR922, CR923, CR924, CR925, CR926, CR927, CR928, CR929, CR930, CR931, CR932, CR933, CR934, CR935, CR936, CR937, CR938, CR939, CR940, CR941, CR942, CR943, CR944, CR945, CR946, CR947, CR948, CR949, CR950, CR951, CR952, CR953, CR954, CR955, CR956, CR957, CR958, CR959, CR960, CR961, CR962, CR963, CR964, CR965, CR966, CR967, CR968, CR969, CR970, CR971, CR972, CR973, CR974, CR975, CR976, CR977, CR978, CR979, CR980, CR981, CR982, CR983, CR984, CR985, CR986, CR987, CR988, CR989, CR990, CR991, CR992, CR993, CR994, CR995, CR996, CR997, CR998, CR999, CR1000.

-01 ASSY SHOWN
 -02

ADD JUMPER
 VIEW A
 -02 ASSY ONLY

DATE	DESCRIPTION	BY	DATE	APPROVED
1	REVISED AND REDRAWN PER ECN 2596	AK	11-7-77	AK
2	REVISED PER ECN N980336	AK	11-17-98	AK

CONTRACT NO.	DATE
FIRST MADE FOR	J. J. BAKER
APPROVAL	
DESIGNED	
CHECKED	
PROJ. ENG.	
DRAWER	

UNLESS OTHERWISE SPECIFIED	400SD 3 PHASE
TOLERANCES ARE IN INCHES	400SD 3 PHASE
FORMA: 1/16" ± 1/32"	400SD 1 PHASE
DRILL: 1/32" ± 1/64"	400SD 1 PHASE
PLATING: PER ECN N980336	400SD 1 PHASE
MATERIAL:	USED ON
NET ASSY:	

DATE	DESCRIPTION	BY	DATE	APPROVED
1	REVISED AND REDRAWN PER ECN 2596	AK	11-7-77	AK
2	REVISED PER ECN N980336	AK	11-17-98	AK

Figure 5-2. Model 400SD/SP Main Board Assembly Drawing

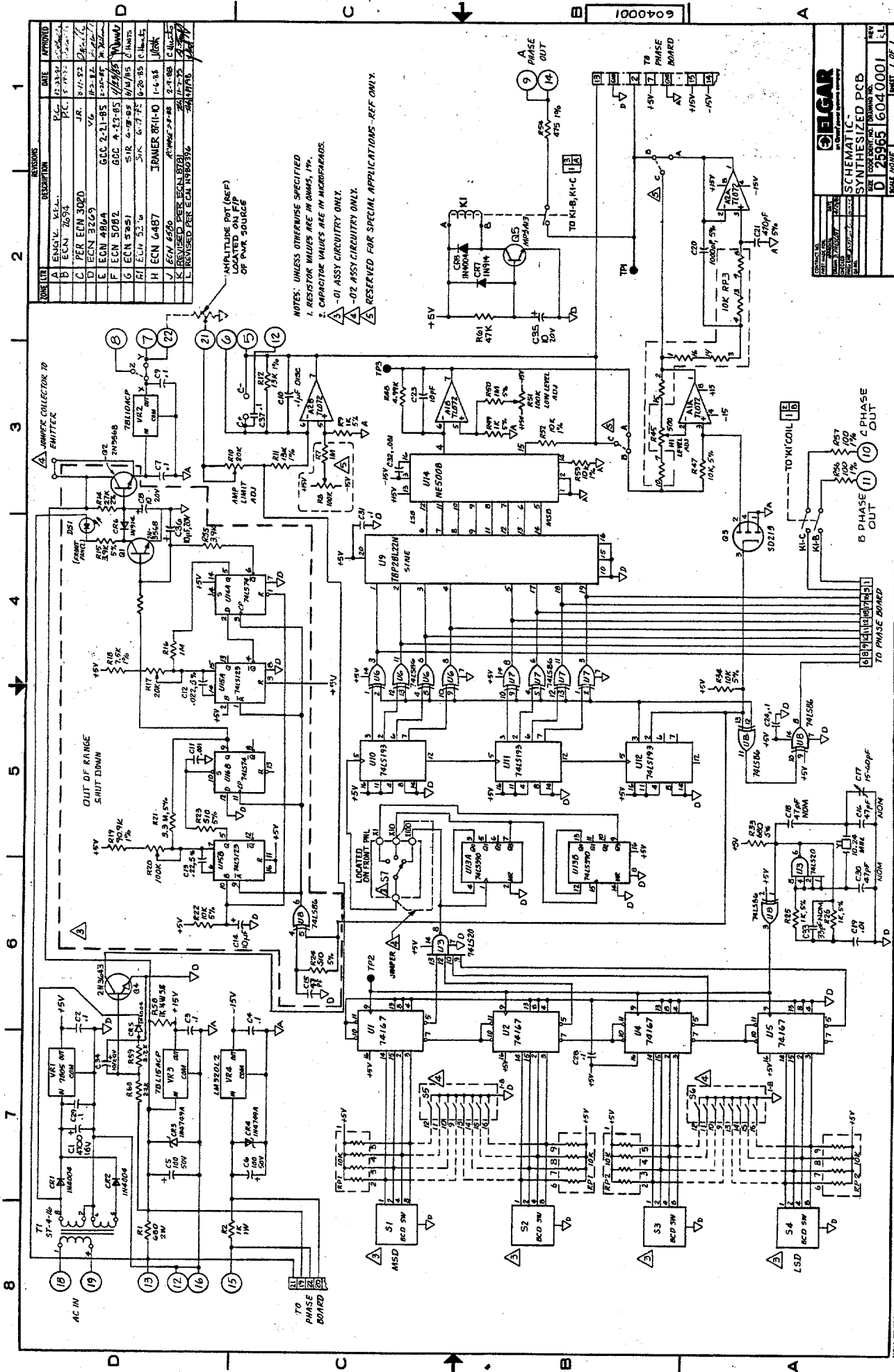

REV	DESCRIPTION	DATE	APPROVED
1	INITIAL REV.	5-13-93	...
2	ECN 7653	5-13-93	...
3	PER ECN 309D	5-13-93	...
4	PER ECN 3269	5-13-93	...
5	PER ECN 4864	5-13-93	...
6	PER ECN 5082	5-13-93	...
7	PER ECN 5281	5-13-93	...
8	PER ECN 5334	5-13-93	...
9	PER ECN 6487	5-13-93	...
10	PER ECN 6526	5-13-93	...
11	PER ECN 6527	5-13-93	...
12	PER ECN 6528	5-13-93	...
13	PER ECN 6529	5-13-93	...
14	PER ECN 6530	5-13-93	...
15	PER ECN 6531	5-13-93	...
16	PER ECN 6532	5-13-93	...
17	PER ECN 6533	5-13-93	...
18	PER ECN 6534	5-13-93	...
19	PER ECN 6535	5-13-93	...
20	PER ECN 6536	5-13-93	...
21	PER ECN 6537	5-13-93	...
22	PER ECN 6538	5-13-93	...
23	PER ECN 6539	5-13-93	...
24	PER ECN 6540	5-13-93	...
25	PER ECN 6541	5-13-93	...
26	PER ECN 6542	5-13-93	...
27	PER ECN 6543	5-13-93	...
28	PER ECN 6544	5-13-93	...
29	PER ECN 6545	5-13-93	...
30	PER ECN 6546	5-13-93	...
31	PER ECN 6547	5-13-93	...
32	PER ECN 6548	5-13-93	...
33	PER ECN 6549	5-13-93	...
34	PER ECN 6550	5-13-93	...
35	PER ECN 6551	5-13-93	...
36	PER ECN 6552	5-13-93	...
37	PER ECN 6553	5-13-93	...
38	PER ECN 6554	5-13-93	...
39	PER ECN 6555	5-13-93	...
40	PER ECN 6556	5-13-93	...
41	PER ECN 6557	5-13-93	...
42	PER ECN 6558	5-13-93	...
43	PER ECN 6559	5-13-93	...
44	PER ECN 6560	5-13-93	...
45	PER ECN 6561	5-13-93	...
46	PER ECN 6562	5-13-93	...
47	PER ECN 6563	5-13-93	...
48	PER ECN 6564	5-13-93	...
49	PER ECN 6565	5-13-93	...
50	PER ECN 6566	5-13-93	...
51	PER ECN 6567	5-13-93	...
52	PER ECN 6568	5-13-93	...
53	PER ECN 6569	5-13-93	...
54	PER ECN 6570	5-13-93	...
55	PER ECN 6571	5-13-93	...
56	PER ECN 6572	5-13-93	...
57	PER ECN 6573	5-13-93	...
58	PER ECN 6574	5-13-93	...
59	PER ECN 6575	5-13-93	...
60	PER ECN 6576	5-13-93	...
61	PER ECN 6577	5-13-93	...
62	PER ECN 6578	5-13-93	...
63	PER ECN 6579	5-13-93	...
64	PER ECN 6580	5-13-93	...
65	PER ECN 6581	5-13-93	...
66	PER ECN 6582	5-13-93	...
67	PER ECN 6583	5-13-93	...
68	PER ECN 6584	5-13-93	...
69	PER ECN 6585	5-13-93	...
70	PER ECN 6586	5-13-93	...
71	PER ECN 6587	5-13-93	...
72	PER ECN 6588	5-13-93	...
73	PER ECN 6589	5-13-93	...
74	PER ECN 6590	5-13-93	...
75	PER ECN 6591	5-13-93	...
76	PER ECN 6592	5-13-93	...
77	PER ECN 6593	5-13-93	...
78	PER ECN 6594	5-13-93	...
79	PER ECN 6595	5-13-93	...
80	PER ECN 6596	5-13-93	...
81	PER ECN 6597	5-13-93	...
82	PER ECN 6598	5-13-93	...
83	PER ECN 6599	5-13-93	...
84	PER ECN 6600	5-13-93	...
85	PER ECN 6601	5-13-93	...
86	PER ECN 6602	5-13-93	...
87	PER ECN 6603	5-13-93	...
88	PER ECN 6604	5-13-93	...
89	PER ECN 6605	5-13-93	...
90	PER ECN 6606	5-13-93	...
91	PER ECN 6607	5-13-93	...
92	PER ECN 6608	5-13-93	...
93	PER ECN 6609	5-13-93	...
94	PER ECN 6610	5-13-93	...
95	PER ECN 6611	5-13-93	...
96	PER ECN 6612	5-13-93	...
97	PER ECN 6613	5-13-93	...
98	PER ECN 6614	5-13-93	...
99	PER ECN 6615	5-13-93	...
100	PER ECN 6616	5-13-93	...
101	PER ECN 6617	5-13-93	...
102	PER ECN 6618	5-13-93	...
103	PER ECN 6619	5-13-93	...
104	PER ECN 6620	5-13-93	...
105	PER ECN 6621	5-13-93	...
106	PER ECN 6622	5-13-93	...
107	PER ECN 6623	5-13-93	...
108	PER ECN 6624	5-13-93	...
109	PER ECN 6625	5-13-93	...
110	PER ECN 6626	5-13-93	...
111	PER ECN 6627	5-13-93	...
112	PER ECN 6628	5-13-93	...
113	PER ECN 6629	5-13-93	...
114	PER ECN 6630	5-13-93	...
115	PER ECN 6631	5-13-93	...
116	PER ECN 6632	5-13-93	...
117	PER ECN 6633	5-13-93	...
118	PER ECN 6634	5-13-93	...
119	PER ECN 6635	5-13-93	...
120	PER ECN 6636	5-13-93	...
121	PER ECN 6637	5-13-93	...
122	PER ECN 6638	5-13-93	...
123	PER ECN 6639	5-13-93	...
124	PER ECN 6640	5-13-93	...
125	PER ECN 6641	5-13-93	...
126	PER ECN 6642	5-13-93	...
127	PER ECN 6643	5-13-93	...
128	PER ECN 6644	5-13-93	...
129	PER ECN 6645	5-13-93	...
130	PER ECN 6646	5-13-93	...
131	PER ECN 6647	5-13-93	...
132	PER ECN 6648	5-13-93	...
133	PER ECN 6649	5-13-93	...
134	PER ECN 6650	5-13-93	...
135	PER ECN 6651	5-13-93	...
136	PER ECN 6652	5-13-93	...
137	PER ECN 6653	5-13-93	...
138	PER ECN 6654	5-13-93	...
139	PER ECN 6655	5-13-93	...
140	PER ECN 6656	5-13-93	...
141	PER ECN 6657	5-13-93	...
142	PER ECN 6658	5-13-93	...
143	PER ECN 6659	5-13-93	...
144	PER ECN 6660	5-13-93	...
145	PER ECN 6661	5-13-93	...
146	PER ECN 6662	5-13-93	...
147	PER ECN 6663	5-13-93	...
148	PER ECN 6664	5-13-93	...
149	PER ECN 6665	5-13-93	...
150	PER ECN 6666	5-13-93	...
151	PER ECN 6667	5-13-93	...
152	PER ECN 6668	5-13-93	...
153	PER ECN 6669	5-13-93	...
154	PER ECN 6670	5-13-93	...
155	PER ECN 6671	5-13-93	...
156	PER ECN 6672	5-13-93	...
157	PER ECN 6673	5-13-93	...
158	PER ECN 6674	5-13-93	...
159	PER ECN 6675	5-13-93	...
160	PER ECN 6676	5-13-93	...
161	PER ECN 6677	5-13-93	...
162	PER ECN 6678	5-13-93	...
163	PER ECN 6679	5-13-93	...
164	PER ECN 6680	5-13-93	...
165	PER ECN 6681	5-13-93	...
166	PER ECN 6682	5-13-93	...
167	PER ECN 6683	5-13-93	...
168	PER ECN 6684	5-13-93	...
169	PER ECN 6685	5-13-93	...
170	PER ECN 6686	5-13-93	...
171	PER ECN 6687	5-13-93	...
172	PER ECN 6688	5-13-93	...
173	PER ECN 6689	5-13-93	...
174	PER ECN 6690	5-13-93	...
175	PER ECN 6691	5-13-93	...
176	PER ECN 6692	5-13-93	...
177	PER ECN 6693	5-13-93	...
178	PER ECN 6694	5-13-93	...
179	PER ECN 6695	5-13-93	...
180	PER ECN 6696	5-13-93	...
181	PER ECN 6697	5-13-93	...
182	PER ECN 6698	5-13-93	...
183	PER ECN 6699	5-13-93	...
184	PER ECN 6700	5-13-93	...
185	PER ECN 6701	5-13-93	...
186	PER ECN 6702	5-13-93	...
187	PER ECN 6703	5-13-93	...
188	PER ECN 6704	5-13-93	...
189	PER ECN 6705	5-13-93	...
190	PER ECN 6706	5-13-93	...
191	PER ECN 6707	5-13-93	...
192	PER ECN 6708	5-13-93	...
193	PER ECN 6709	5-13-93	...
194	PER ECN 6710	5-13-93	...
195	PER ECN 6711	5-13-93	...
196	PER ECN 6712	5-13-93	...
197	PER ECN 6713	5-13-93	...
198	PER ECN 6714	5-13-93	...
199	PER ECN 6715	5-13-93	...
200	PER ECN 6716	5-13-93	...
201	PER ECN 6717	5-13-93	...
202	PER ECN 6718	5-13-93	...
203	PER ECN 6719	5-13-93	...
204	PER ECN 6720	5-13-93	...
205	PER ECN 6721	5-13-93	...
206	PER ECN 6722	5-13-93	...
207	PER ECN 6723	5-13-93	...
208	PER ECN 6724	5-13-93	...
209	PER ECN 6725	5-13-93	...
210	PER ECN 6726	5-13-93	...
211	PER ECN 6727	5-13-93	...
212	PER ECN 6728	5-13-93	...
213	PER ECN 6729	5-13-93	...
214	PER ECN 6730	5-13-93	...
215	PER ECN 6731	5-13-93	...
216	PER ECN 6732	5-13-93	...
217	PER ECN 6733	5-13-93	...
218	PER ECN 6734	5-13-93	...
219	PER ECN 6735	5-13-93	...
220	PER ECN 6736	5-13-93	...
221	PER ECN 6737	5-13-93	...
222	PER ECN 6738	5-13-93	...
223	PER ECN 6739	5-13-93	...
224	PER ECN 6740	5-13-93	...
225	PER ECN 6741	5-13-93	...
226	PER ECN 6742	5-13-93	...
227	PER ECN 6743	5-13-93	...
228	PER ECN 6744	5-13-93	...
229	PER ECN 6745	5-13-93	...
230	PER ECN 6746	5-13-93	...
231	PER ECN 6747	5-13-93	...
232	PER ECN 6748	5-13-93	...
233	PER ECN 6749	5-13-93	...
234	PER ECN 6750	5-13-93	...
235	PER ECN 6751	5-13-93	...
236	PER ECN 6752	5-13-93	...
237	PER ECN 6753	5-13-93	...
238	PER ECN 6754	5-13-93	...
239	PER ECN 6755	5-13-93	...
240	PER ECN 6756	5-13-93	...
241	PER ECN 6757	5-13-93	...
242	PER ECN 6		

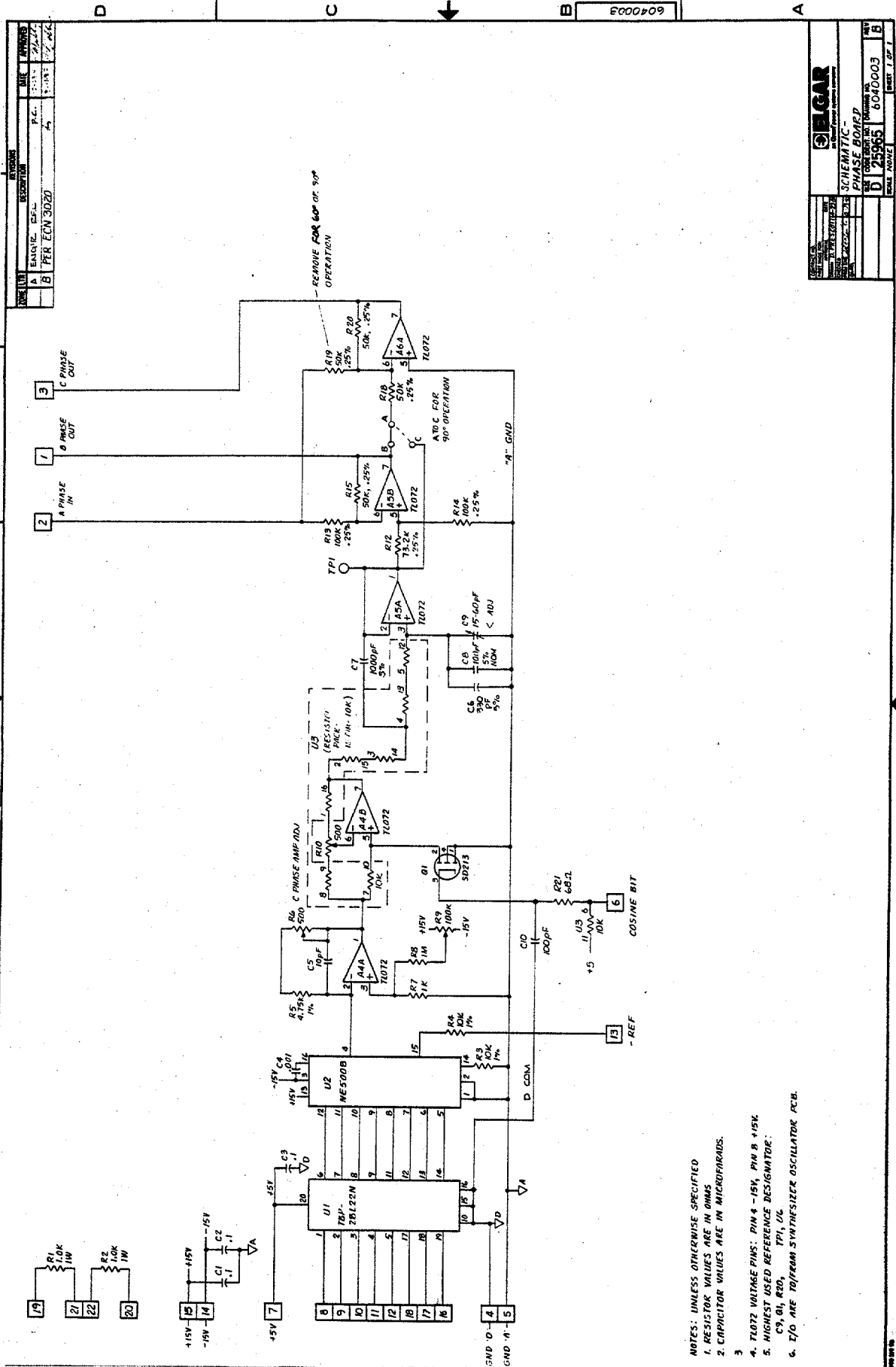

- NOTES: UNLESS OTHERWISE SPECIFIED
 1. RESISTOR VALUES ARE IN OHMS
 2. CAPACITOR VALUES ARE IN MICROFARADS.
 3.
 4. TL072 VOLTAGE PINS: PIN 4 - 15V, PIN 5 - 15V
 5. HIGHEST USED REFERENCE DESIGNATOR:
 C9, R1, R20, TPI, U3
 6. U7/D ARE TO/FRM SYNTHESIZER OSCILLATOR PCB.

Figure 5-3. Model 400SD/SP Phase Board Schematic

5-715-8

REVISIONS			
ZONE LTR	DESCRIPTION	DATE	APPROVED
D	REVISED AND REDRAWN PER ECN 78665A	11/11/76	[Signature]
E	REVISED PER ECN 8783	11/17/76	[Signature]

1 2 3 4

SEE DETAIL A
(FOR U1, U3, U5)

ADD 819-249-IF
3 PLCS

51 52 53
2 PLCS

40 FARBSIDE
3 PLCS

5

3 2 REQ'D

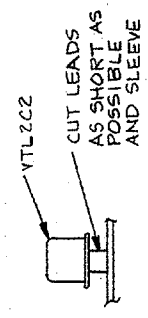
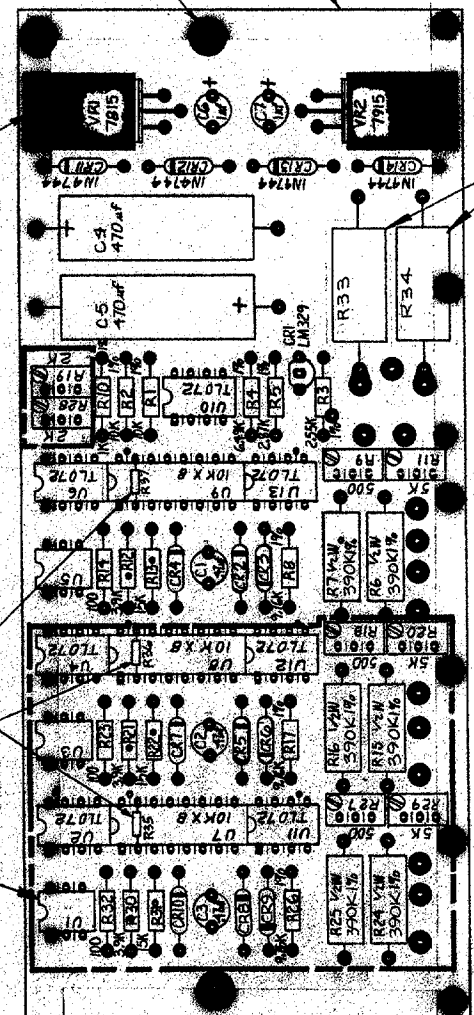

DETAIL A
(U1, 3, 5)

-01 SHOWN (3 PHASE)
-02 SAME EXCEPT COMPONENTS
SHOWN IN PHANTOM NOT INSTALLED
(1 PHASE)

INSTALL 1K, 2W RESISTORS FOR SINGLE PHASE, 560-Ω, 2W FOR 3-PHASE

2. DIODES ARE IN 9/14.

1. RESISTORS ARE IN OHMS, 1/4W, 5%.

NOTES: UNLESS OTHERWISE SPECIFIED.



ASSY, SERVO BOARD,
400SD/SP

CONTRACT NO.	FIRST MADE FOR	APPROVAL	DATE
			8-20-82
UNLESS OTHERWISE SPECIFIED - DIMENSIONS IN INCHES	DECIMALS	FRACTIONS	ANGLES
	XX ± .03	± 1/32	± 1/2°
	XXX ± .010		
	DO NOT SCALE THIS DRAWING		
MATERIAL:	400 SP		
FINISH:	100 SD		
APPLICATION	USED ON		
THE INFORMATION DISCLOSED HEREIN WAS ORIGINATED BY AND IS THE PROPERTY OF ELGAR CORPORATION AND IS NOT TO BE REPRODUCED OR TRANSMITTED IN ANY FORM OR BY ANY MEANS, ELECTRONIC OR MECHANICAL, INCLUDING PHOTOCOPYING, RECORDING, OR BY ANY INFORMATION STORAGE AND RETRIEVAL SYSTEM. ELGAR CORPORATION RESERVES ALL PATENT, TRADEMARK, AND COPYRIGHT RIGHTS. REPRODUCTION WITHOUT PERMISSION IS PROHIBITED.			

REV	5040004	E
CODE IDENT. NO.	5040004	
DATE	5-11/5-12	
SCALE		SHEET 1 OF 1

5040004

REV	DATE	DESCRIPTION	APPROVED
1	11-1-52	ENG'R RELEASE	
2	11-1-52	REVISED PER EGN 7805	

SCHEMATIC - SERVO BOARD 400SD/SP	
SIZE D CODE IDENT NO 25965 DRAWING NO 6040004	SCALE 1 OF 1 REV B

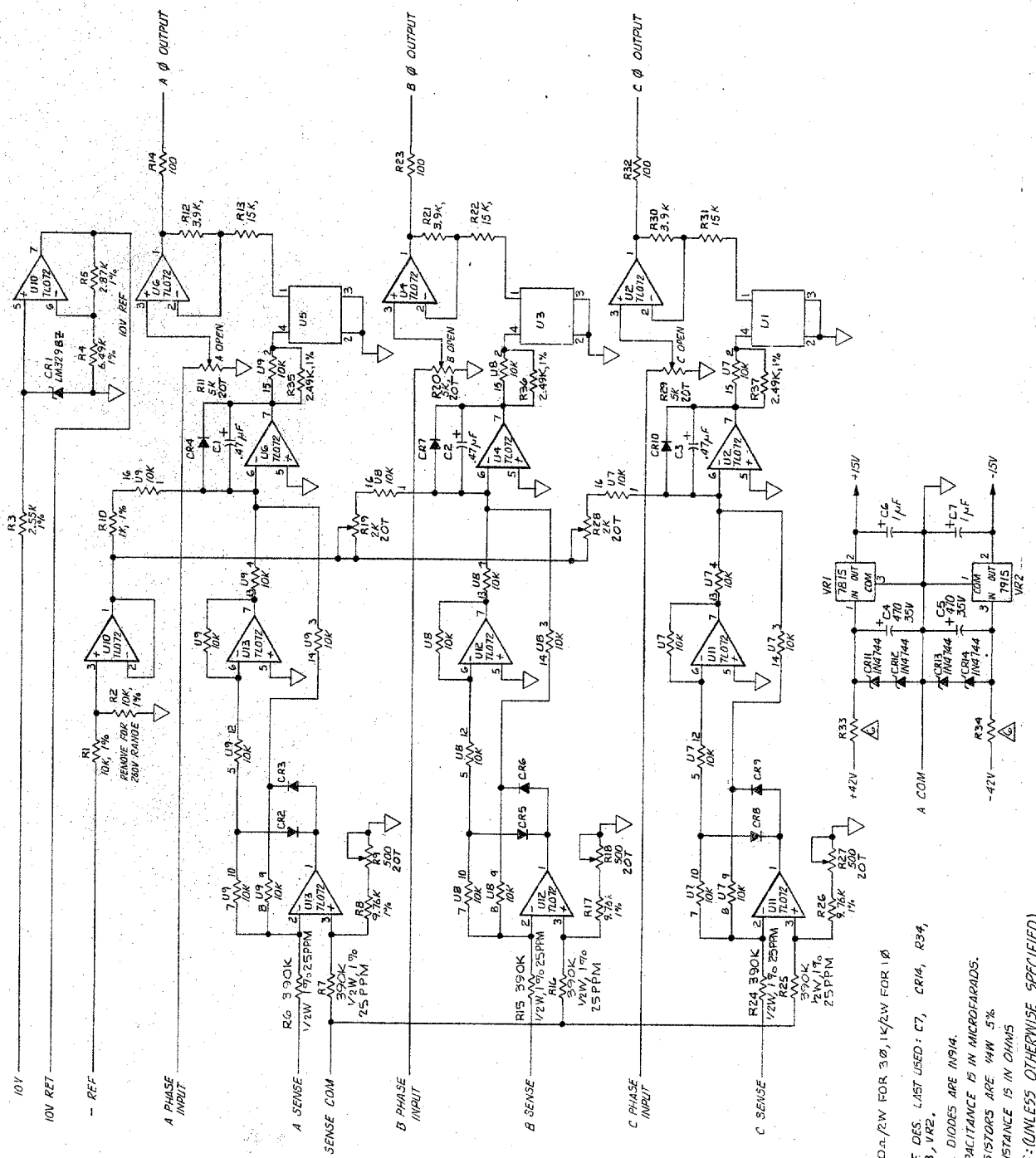

- 5. REF DES. LAST USED: C7, CR14, R34, U13, VR2.
- 6. ALL DIODES ARE IN914.
- 7. CAPACITANCE IS IN MICROFARADS.
- 8. RESISTORS ARE 1/4W 5%.
- 9. RESISTANCE IS IN OHMS.

NOTES: (UNLESS OTHERWISE SPECIFIED)